



**infento**

AGE: 7-14 YEARS  
MAX. LOAD: 154 lbs / 70KG  
LENGTH: 125 CM - 165 CM  
TIME TO BUILD: 2 HRS



**DIFFICULTY**



**ICE BREAKER** <sup>G2</sup>

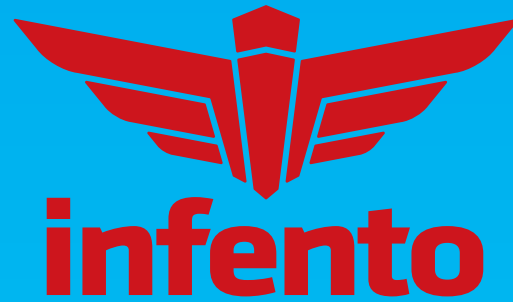

World's first real constructible rides



**WARNING - IMPORTANT NOTICE TO PARENTS**

Before you start constructing and use our product, please carefully read the following safety warning. This safety warning and manual contains important information relating to your child's safety. It is your responsibility to review this information with your child and make sure they are fully aware of all the warnings before they start riding. Failure to follow instructions and safety precautions can result in serious injury or death.

You can find a digital copy of all the manuals  
at the following web address:

**[www.infento.com](http://www.infento.com)**

**SUSTAINABILITY IS ONE OF OUR COMPANY'S PILLARS** AND  
THEREFORE WE OFFER **DIGITAL MANUALS** ONLY. WOULD YOU STILL LIKE  
TO PRINT THIS MANUAL? WE SUGGEST TO PRINT IT IN BLACK AND WHITE  
AND TO PRINT 2 OR 4 PAGES PER SHEET.

# SAFETY SECTION



## **WARNING! PARENTAL SUPERVISION AND APPROPRIATE USE**

Like any moving product, rides made from Infento parts can be dangerous if due care and attention is not paid. To reduce the risk of serious injury: use only under close adult supervision. Parents must review the following warnings and instructions with each Infento ride that is being build. It is your responsibility to review this information and make sure that all riders understand all warnings, cautions, instructions and safety topics, and assure that young riders are able to safely and responsibly use this product. Infento recommends that you periodically review and reinforce the information in this manual with younger riders, and that you inspect and maintain your child's Infento rides to insure their safety.

## **WARNING! RIDING ON INFENTO RIDES CAN BE A DANGEROUS ACTIVITY**

Riding on Infento rides can be a dangerous activity. Certain conditions may cause the equipment to fail without fault of the manufacturer. Rides made from Infento parts can and are intended to move, and it is therefore possible to lose control, fall off and/or get into dangerous situations that no amount of care, instruction or expertise can eliminate. If such things occur you can be seriously injured or die, even when using safety equipment and other precautions. Ride at your own risk and use common sense.

## **WARNING! NO LIABILITY FOR CONSTRUCTED RIDES THAT DIFFER FROM OUR MANUALS**

The rides that you can find in our manuals have been tested by official independent testing agencies.

We will not be responsible or liable, directly or indirectly, in any way for any loss or damage of any kind incurred as a result of your decision to build constructions or rides that differ from the official rides that we show in our manuals.

### ASSEMBLY – SUBSECTION

## **WARNING! OUR KITS CONTAIN SMALL PARTS**

This package contains small parts which, before assembly, present a choking hazard to children under the age of three. Care should be taken during unpacking and assembly to insure that all small parts and plastic bags are accounted for and kept out of the reach of children.

## **WARNING! TO AVOID SERIOUS INJURY:**

1. Toys are to be assembled by an adult using Infento manuals.
2. All fasteners (bolts and nuts) should be fully tightened.
3. It is the responsibility of the adult who assembles this bicycle to properly install all parts included in the factory sealed shipping carton and to make the adjustments to the functional parts such as handle bar and seat and chain when necessary.

### USE – SUBSECTION

## **WARNING! TO AVOID SERIOUS INJURY:**

1. Continuous adult supervision is required.
2. Only ride constructed rides that have been built according to the instructions given in the official

Infento manual.

3. Never exceed the maximum weight. You can find the maximum weight for every specific ride in our manual.
4. Always check the manual to see the minimum and maximum age as well as the minimum and maximum length for every specific ride.
5. Always wear safety equipment such as a helmet, knee pads and elbow pads. We recommend riders always wear a properly fitted helmet that complies with local or national guidelines or laws. Keep chinstrap of helmet securely buckled.
6. Always wear closed toed shoes (lace-up shoes with rubber soles), never ride barefooted or in sandals, and keep shoe laces tied and out of the way of the wheels.
7. Avoid streets and surfaces with water, sand, gravel, dirt, leaves, and other debris. Wet weather impairs traction, braking and visibility.
8. Excessive exposure to sunlight, temperatures below 0 degrees Celsius, water, sand, gravel, dirt, leaves, and other debris can damage, shrink, expand or weaken parts. Keep your ride in a dry environment with proper heating.
9. Avoid sharp bumps, drainage grates and sudden surface changes. Your Infento ride may suddenly stop.
10. Ride on smooth, paved surfaces away from motor vehicles. Wet, slick or uneven and rough surfaces may impair traction and contribute to possible accidents.
11. Never risk damaging surfaces, such as carpet or flooring, by use of an Infento ride indoors.
12. Never use near motor vehicles, streets, roadways, alleys, swimming pool areas, hills, steps, sloped driveways, inclines and public highways.
13. Watch out for pedestrians, skaters, skateboards, scooters, bikes, children or animals who may enter your path, and respect the rights and property of others.

14. Avoid excessive speed associated with downhill rides.

15. Do not use at night or in periods with reduced visibility.
16. Before every use, please make sure that the complete ride and all joints have been assembled tightly, as with use, joints may wear out.
17. Before using your Infento ride, please check that the screws are tightened securely.
18. It's your own responsibility if you modify the product other than manufacturer's instructions.
19. Maintain a hold on the handlebars at all times.
20. Brake will get hot from continuous use. Do not touch after braking.
21. Periodically check hardware and tighten if necessary. Replace worn or broken parts immediately.
22. Skill is required to avoid falls or collision causing injury to the user and third parties.
23. Check operation of breaks every time before bicycle is ridden.
24. Check local laws before you start with riding.
25. Never tow wagons, other vehicles, or children on skates or skateboards.
26. Make certain that anyone who uses an Infento ride has been fully instructed in its operation.
27. Instruct your child on how to use the breaks.
28. Do not perform stunts.
29. Never use headphones or a cell phone when riding.
30. Only one rider at a time on an Infento ride.
31. Do not allow children to stand on the product at any time.

**FAILURE TO USE COMMON SENSE AND HEED THE ABOVE WARNINGS INCREASES RISK OF SERIOUS INJURY. USE WITH APPROPRIATE CAUTION AND SERIOUS ATTENTION TO SAFE OPERATION.**

# SAFETY SECTION



## OUR KITS CONTAIN SMALL PARTS

This package contains small parts which, before assembly, present a choking hazard to children under the age of three. Care should be taken during unpacking and assembly to insure that all small parts and plastic bags are accounted for and kept out of the reach of children.

## QUESTIONS? HELP NEEDED?

You can email us at:  
**support@infento.com**  
and our team will assist you as soon as possible.



## MAINTENANCE | INSTRUCTION



1. Oil or grease moving parts periodically.
2. Check nuts and bolts often and tighten if necessary.
3. Any parts showing evidence or wear should be replaced immediately.
4. Follow closely the assembly instructions pertaining to the proper adjustments of parts
5. Periodically check the brake system for proper function
6. Periodically check the steering mechanism for proper function
7. Check the air pressure in the tires to be the amount specified in the manual
8. Periodically check the bicycle's tooth belt to be sure that it is not too loose which could allow the chain to slip off the sprockets.

### INCLUDED TOOLS



**4 x Allen key**  
3, 4, 5, 6 mm



**1 x Handtool**  
for Allen keys

### RECOMMENDED ADDITIONAL TOOLS



**1 x Tapeline**

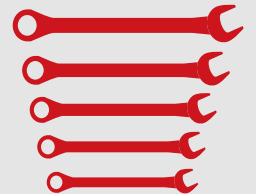

**5 x Wrench**  
10, 13, 14, 15, 19 mm



### One-Way Build

Build solo or as a collaborative team of two. As a team one can collect the parts and give a helping hand where needed while the other does assembly. You can change roles whenever you like.



### Two-Way Build

You are with two or more people. You're all skilled enough to build separate constructions. Everyone done? Combine constructions to form the complete Ride!

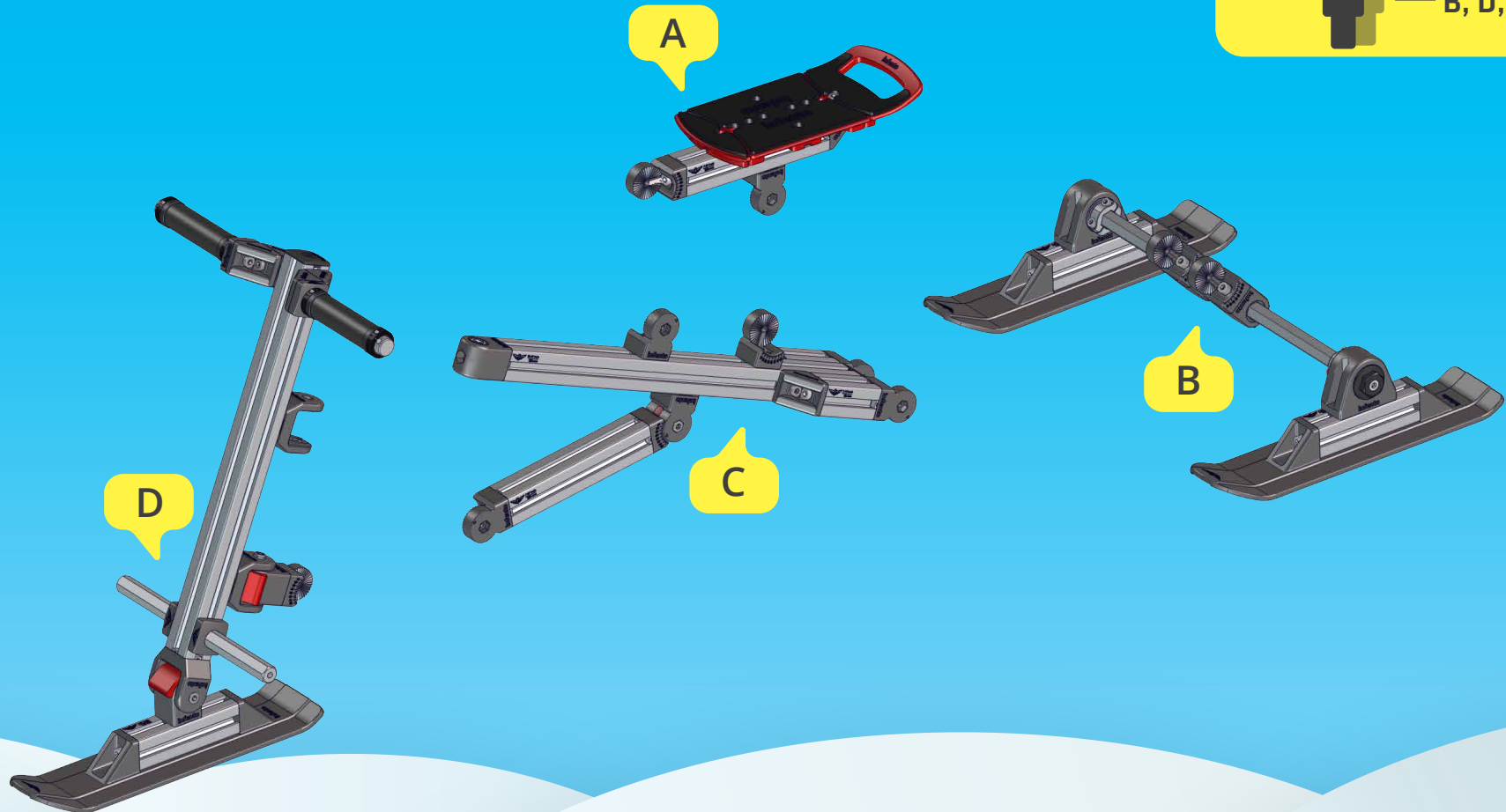
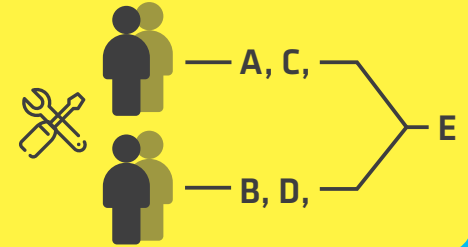

# TOP 3 REQUIREMENTS MAKING A GREAT INFENTO EXPERIENCE:



1

**Tighten bolts with full force (15Nm) to prevent them from coming loose.**

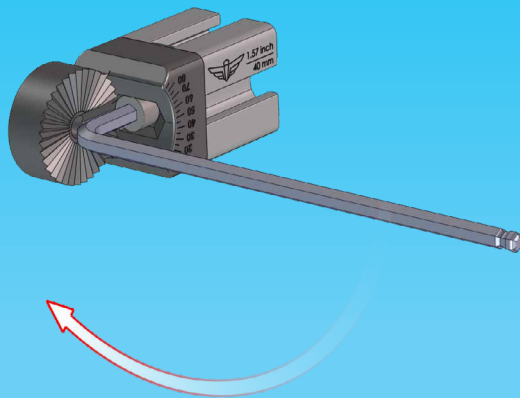

2

**Constructing and playing always under supervision of an adult.**



3

**Check frequently if all parts are still firmly tightened and function properly.**



  
**A.1**

Add a small droplet of threadlock to secure the bolts





7,87 "  
200 mm



M8x20

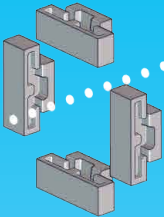
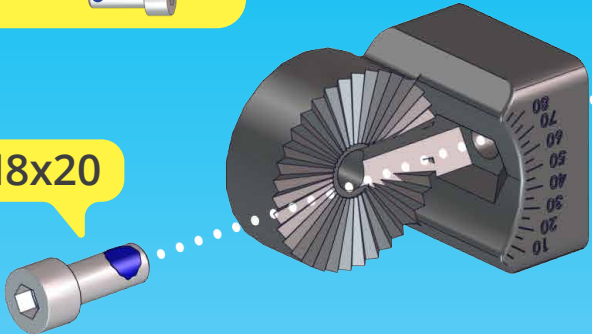

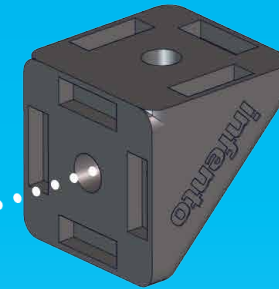
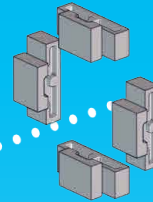
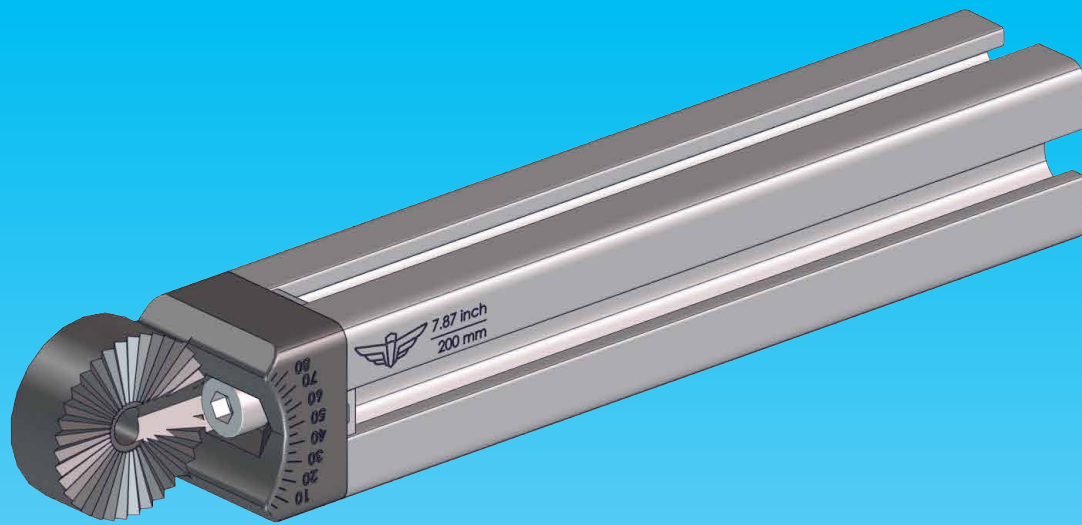

M8x20  
LOW HEAD

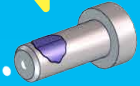

Add a small droplet of threadlock to secure the bolts



  
**A.3**

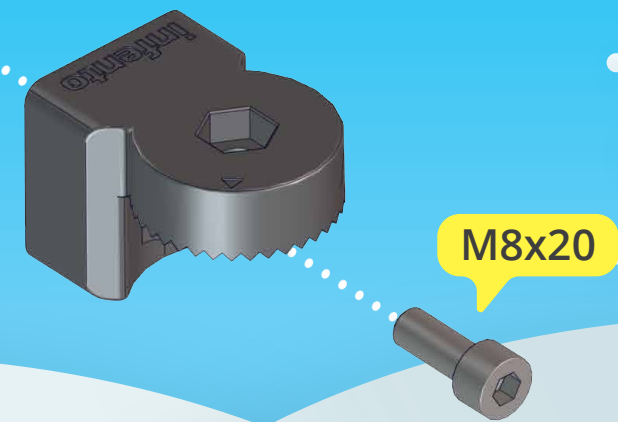
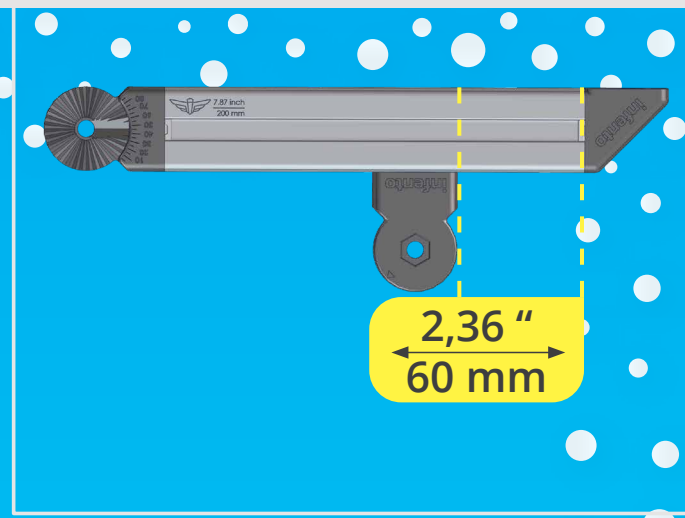
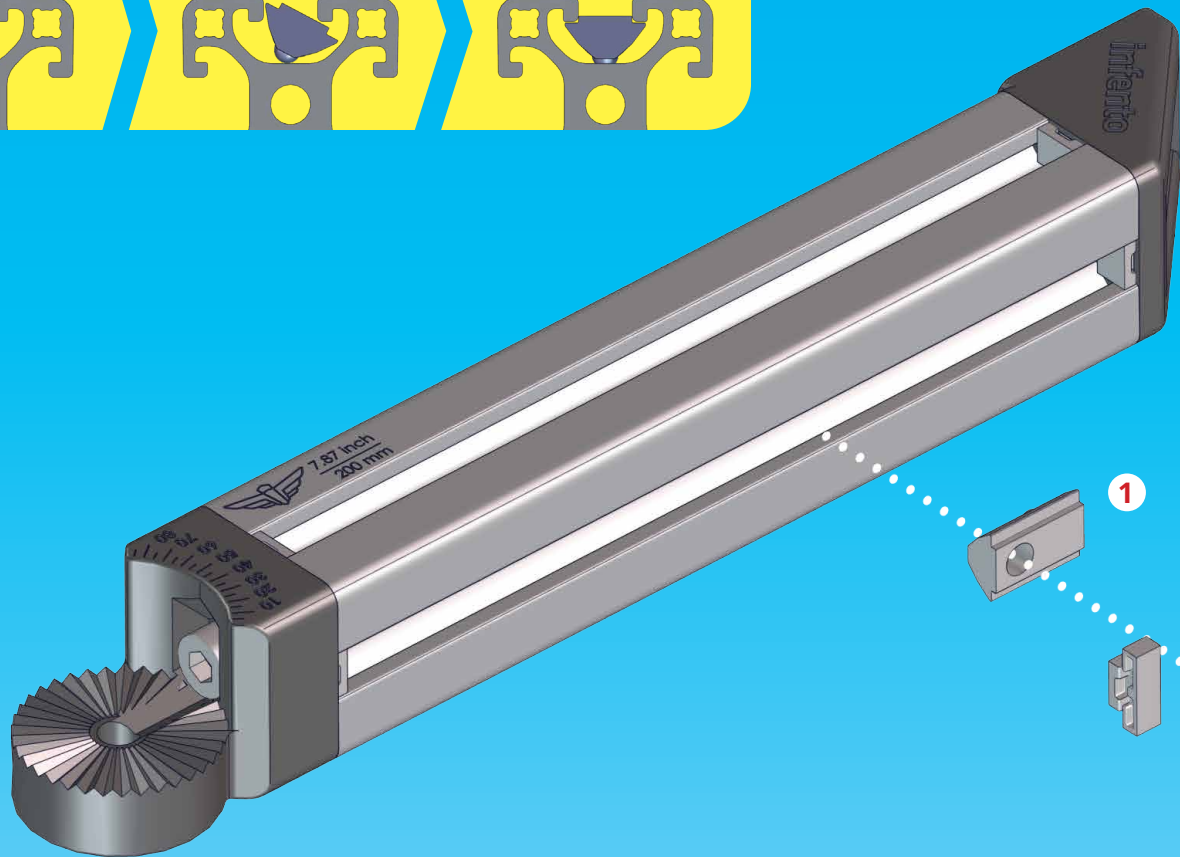
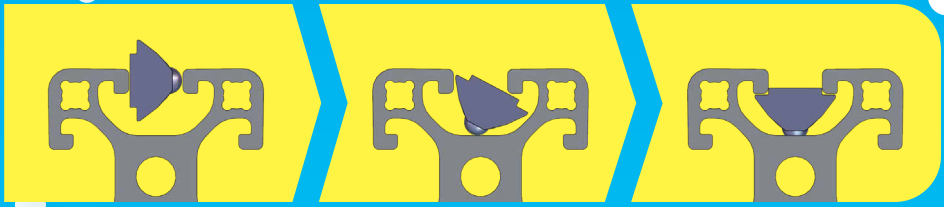

  
**A.4**

1

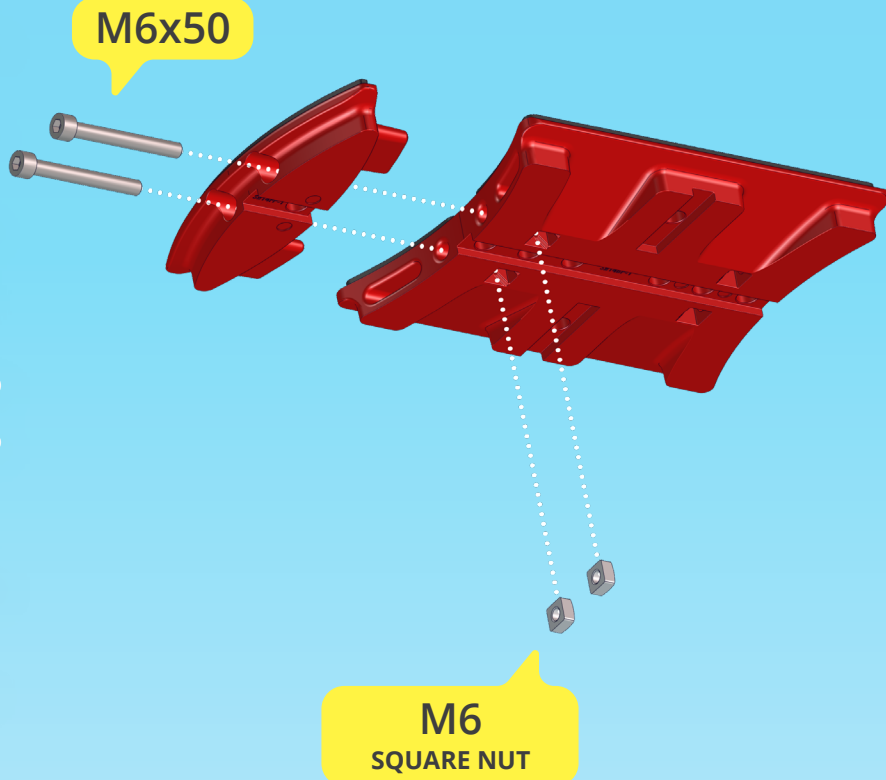

2

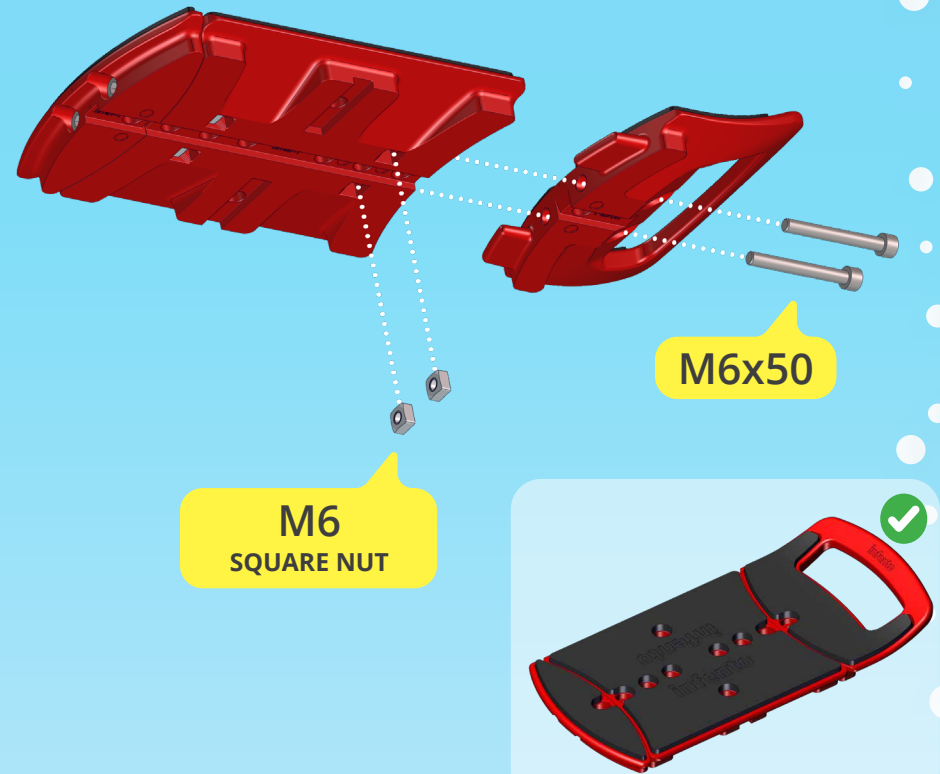

If you don't have this part, go to the next step.

  
**A.5**

Add a small droplet of threadlock to secure the bolts

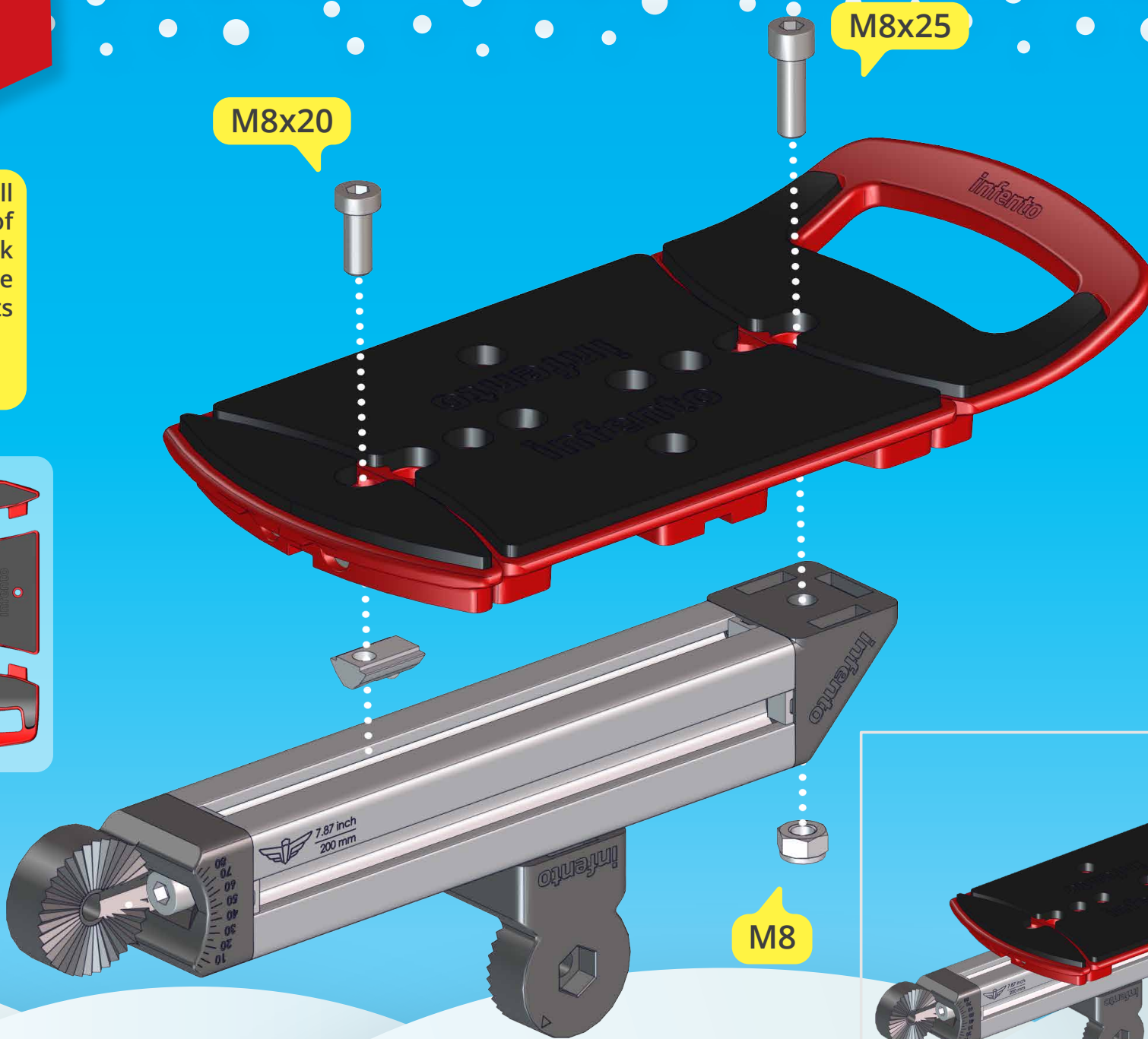
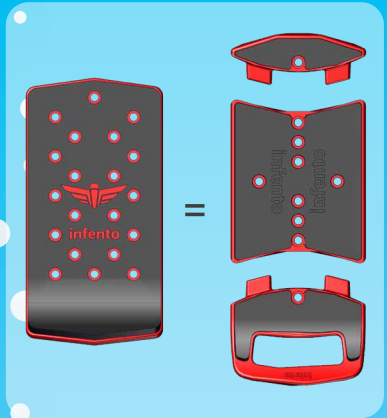

  
**B.1**

**M8  
LOCKNUT**

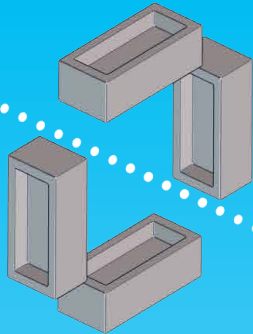
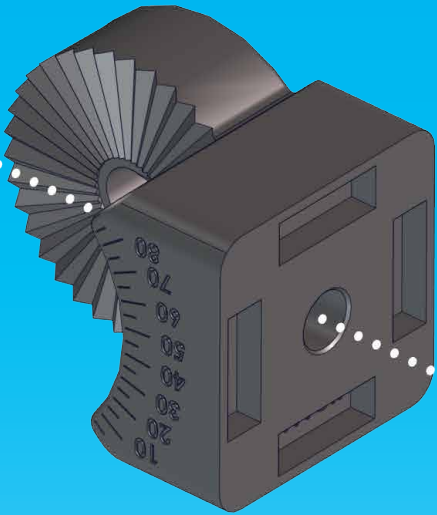
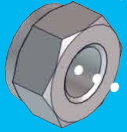

**2x**

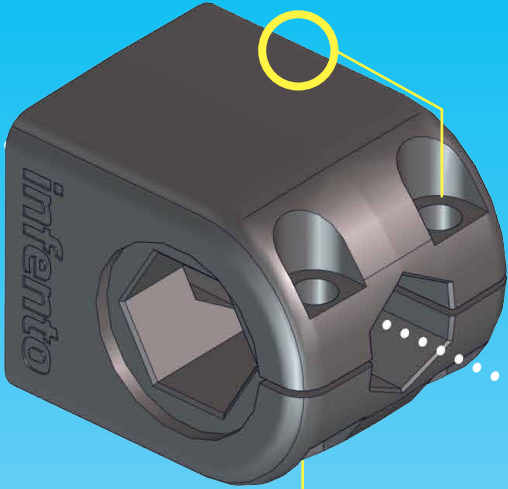

**M8x25**

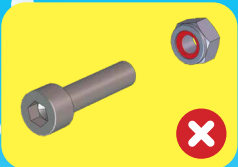
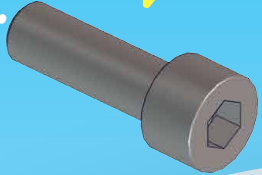



21,65 "  
550 mm

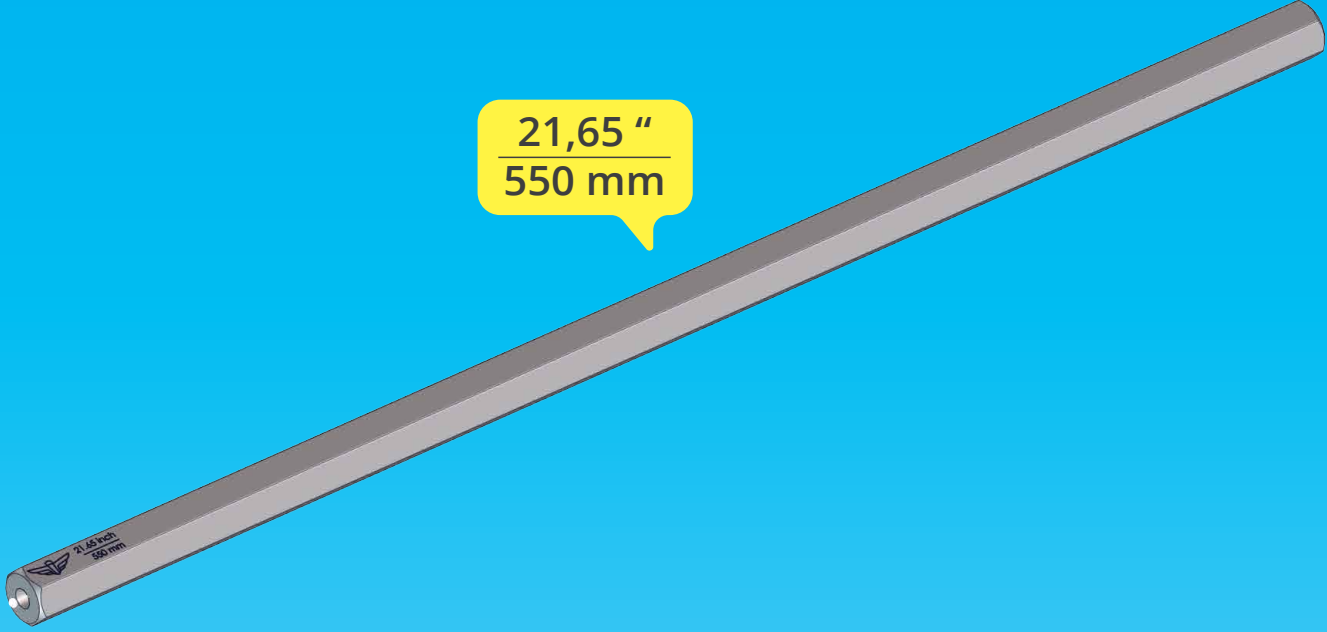
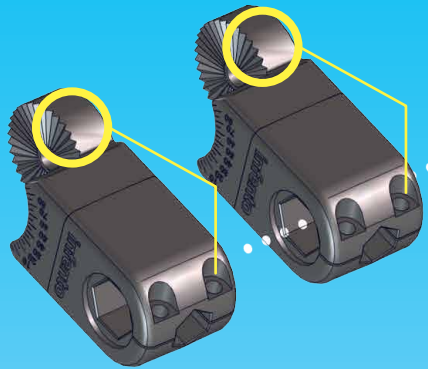



M6x25

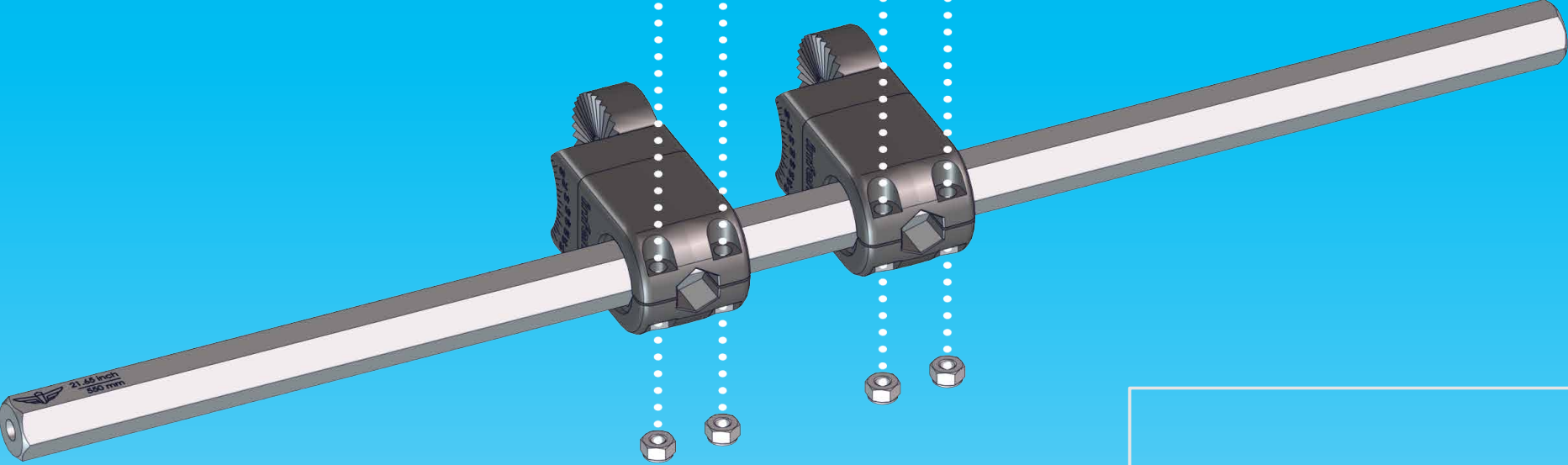

M6  
LOCKNUT

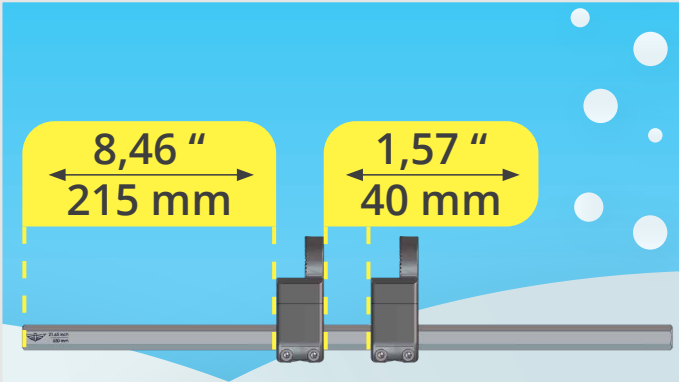



**B.4**

5,51 "  
140 mm



Add a small droplet of threadlock to secure the bolts



M8x20

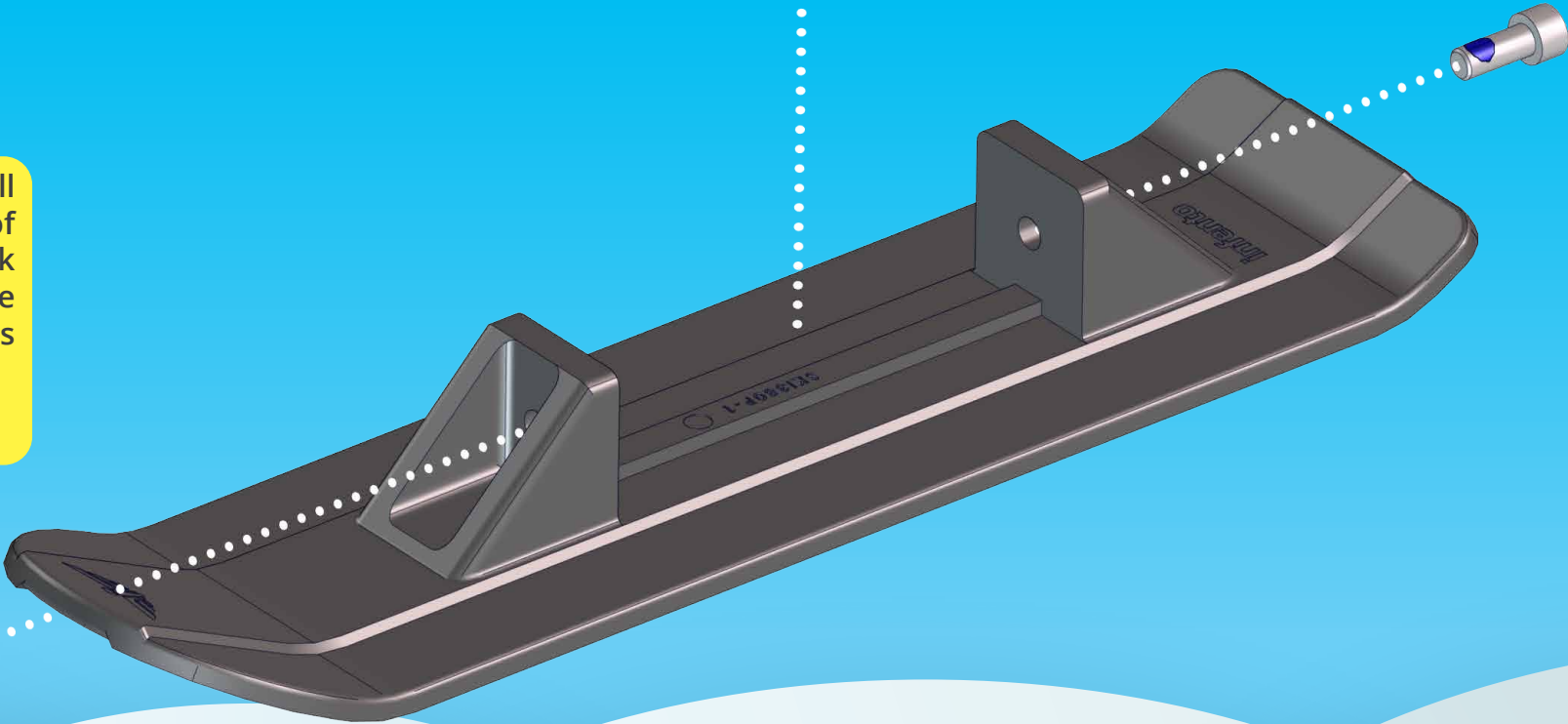
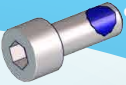



M8x20

Add a small droplet of threadlock to secure the bolts

1,18"  
30 mm

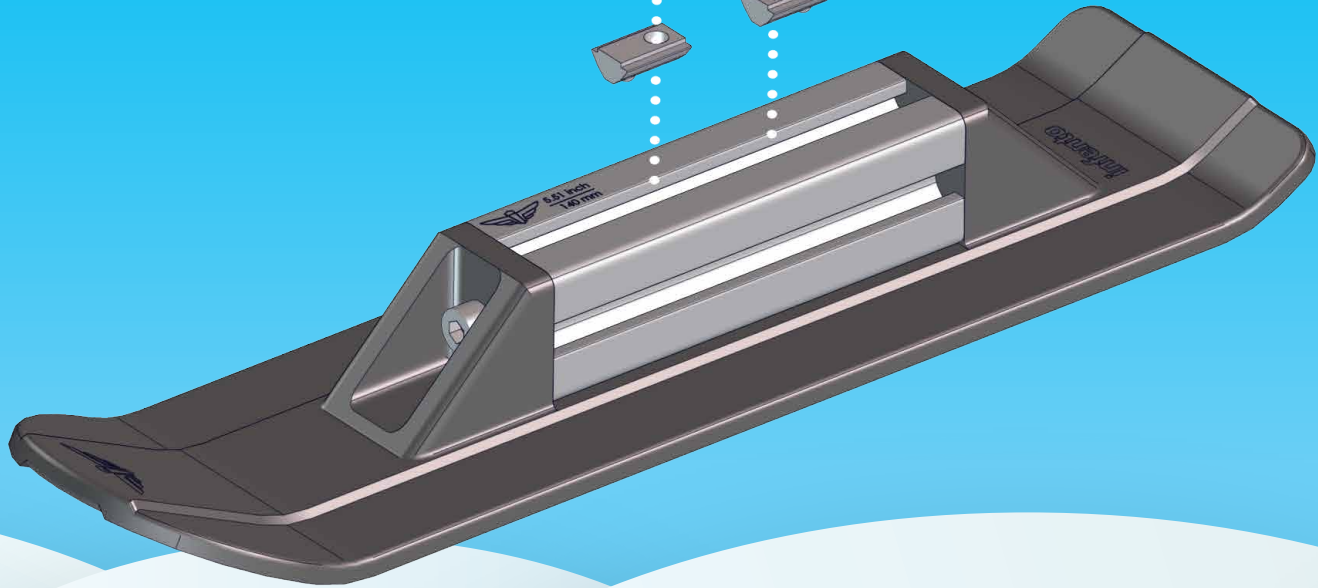
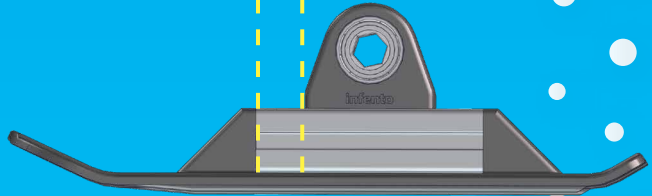





**B.6**

Add a small droplet of threadlock to secure the bolts



**1 mm  
SPACER**

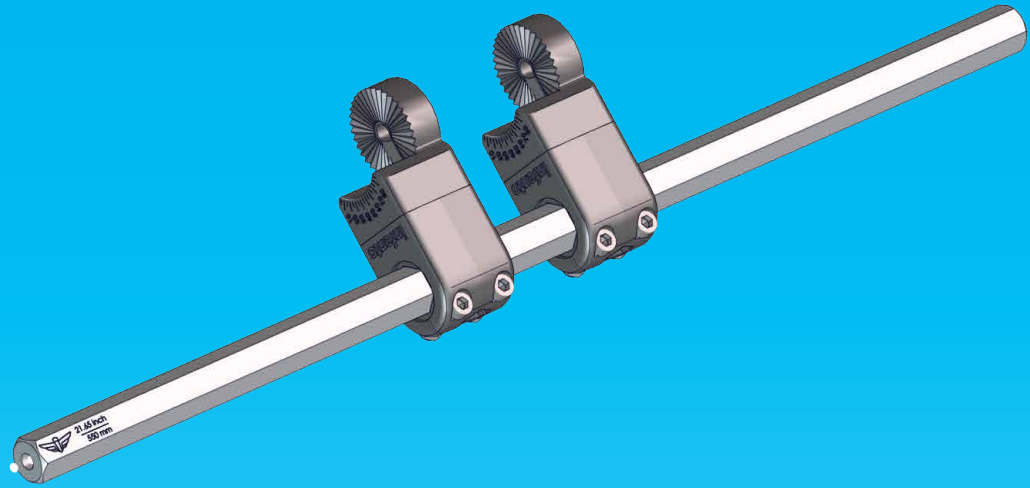

**M8x20**

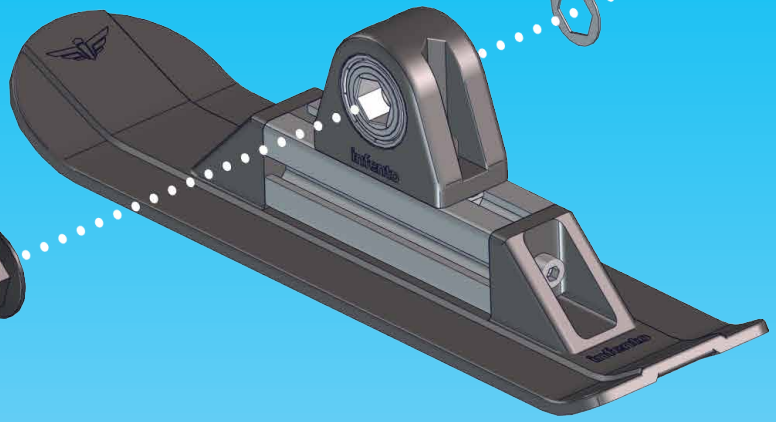



M6x20

Add a small droplet of threadlock to secure the bolts



Clamping part WITHOUT THREAD

Clamping part WITH THREAD

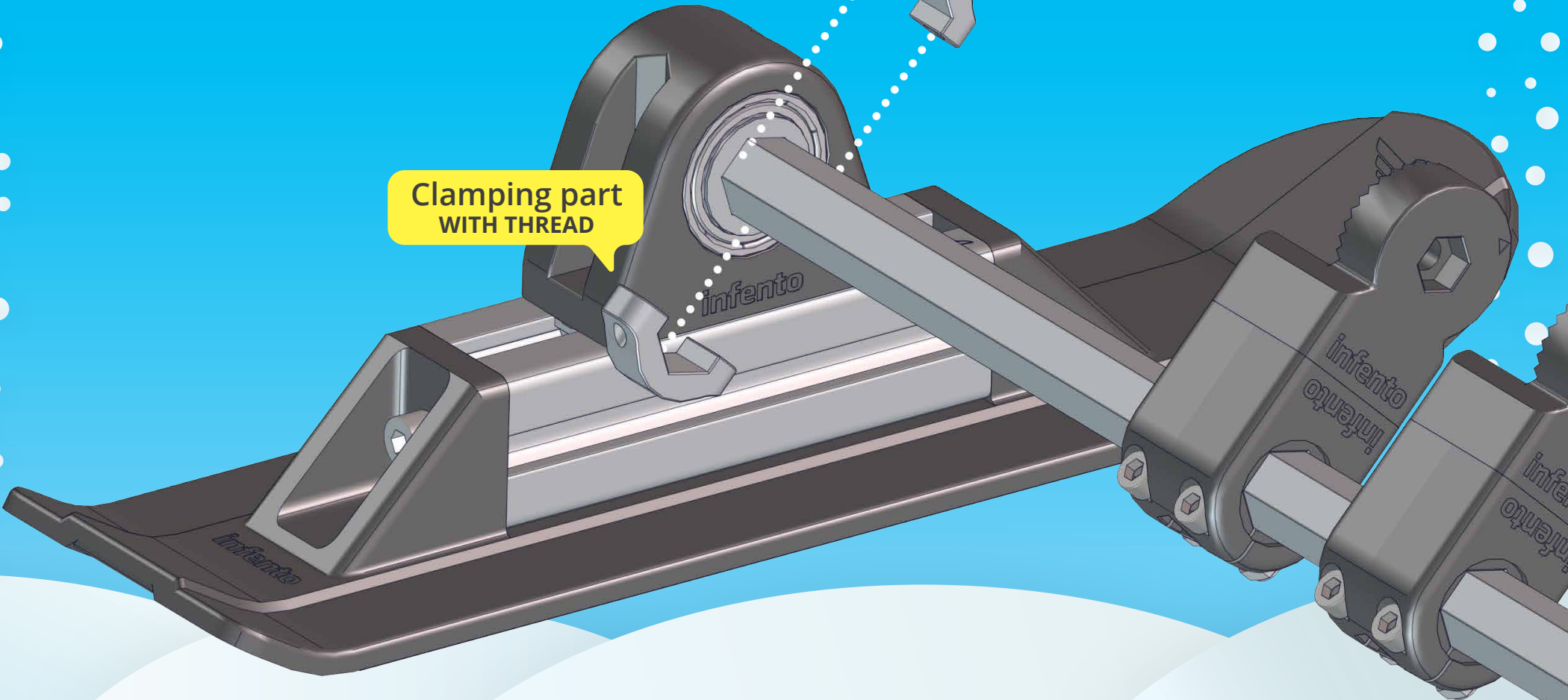



**B.8**

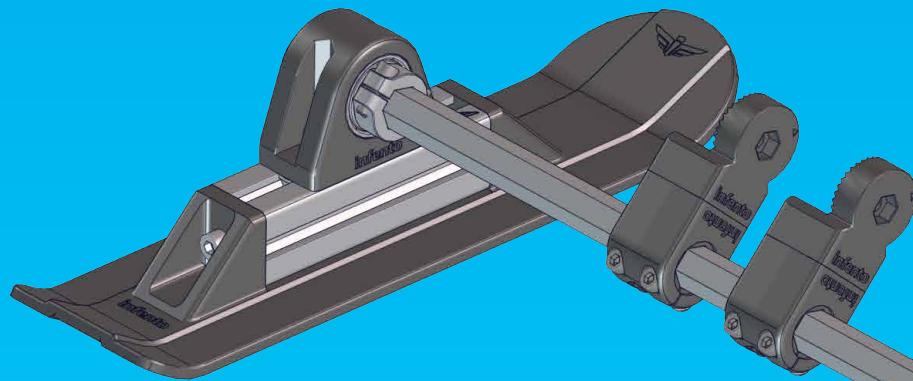

**1 mm  
SPACER**

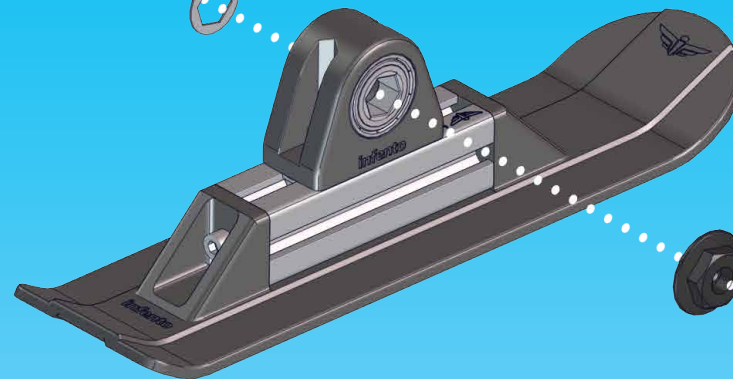

**M8x20**

Add a small droplet of threadlock to secure the bolts



**B.9**



Add a small droplet of threadlock to secure the bolts



M6x20



Clamping part WITH THREAD



Clamping part WITHOUT THREAD

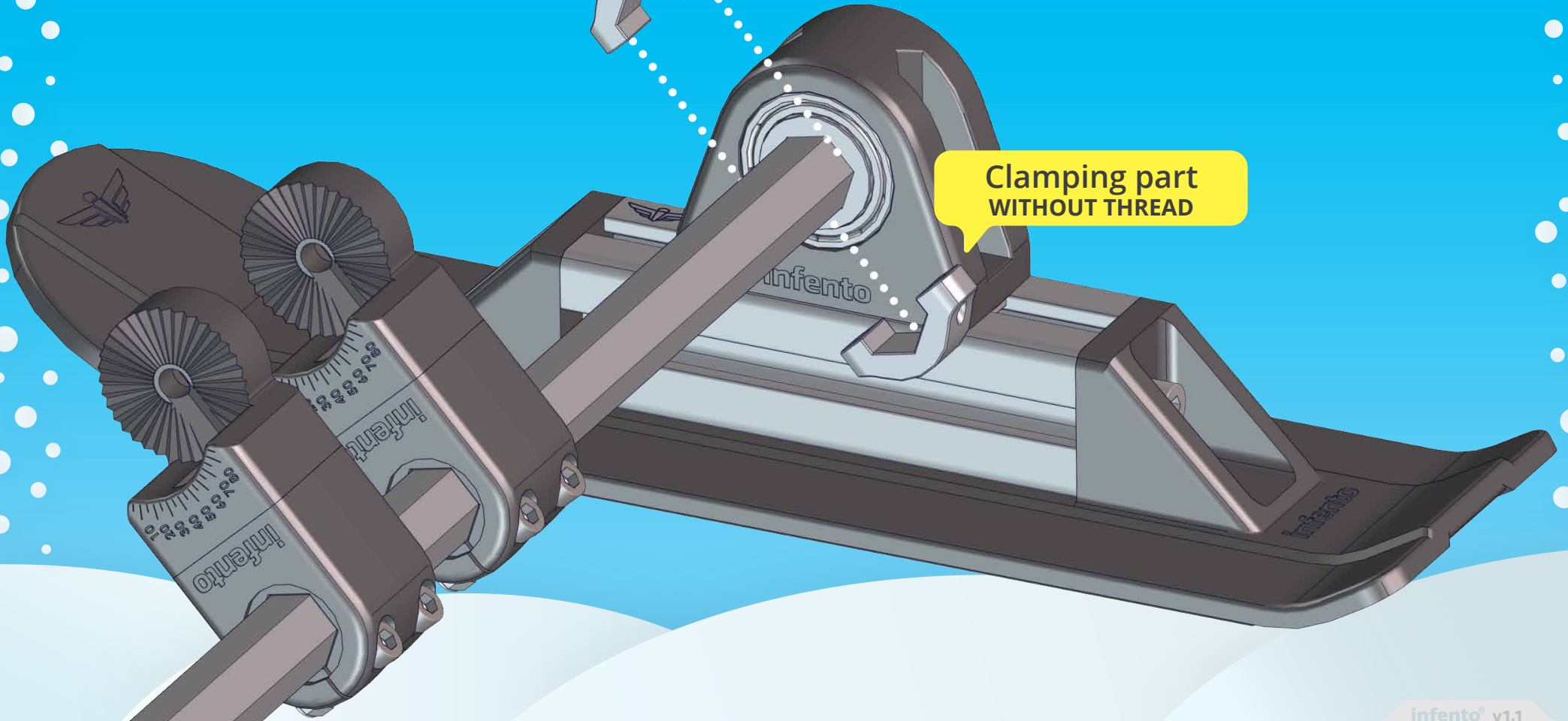



# C.1

1 If you don't have this profile in your kit, make one using the following steps

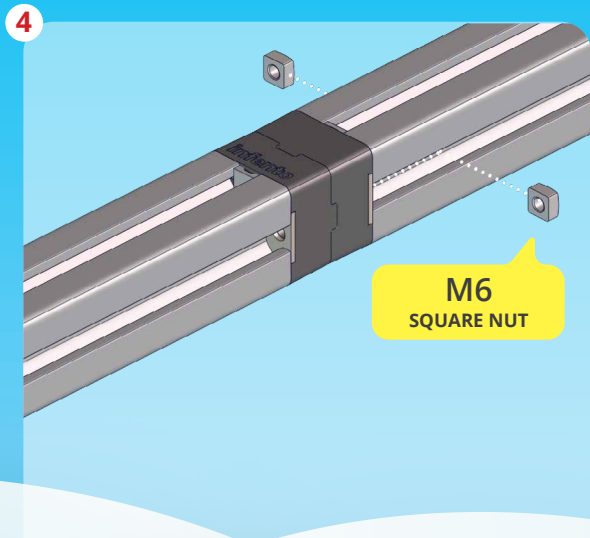
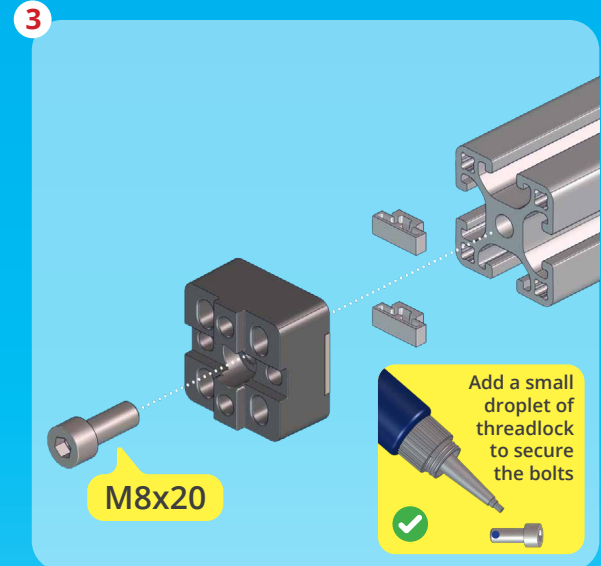
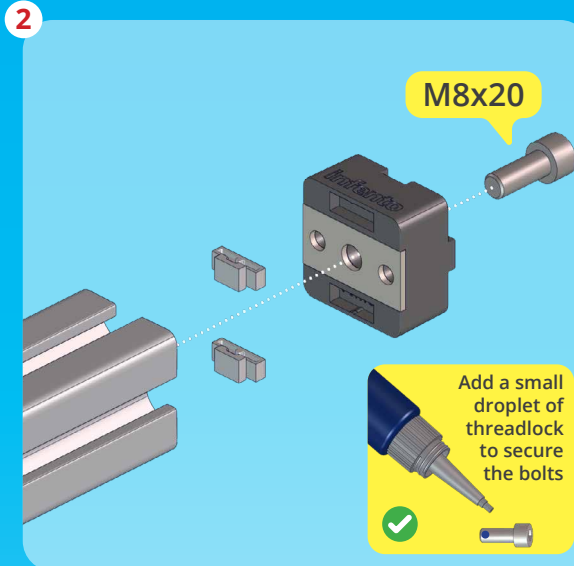
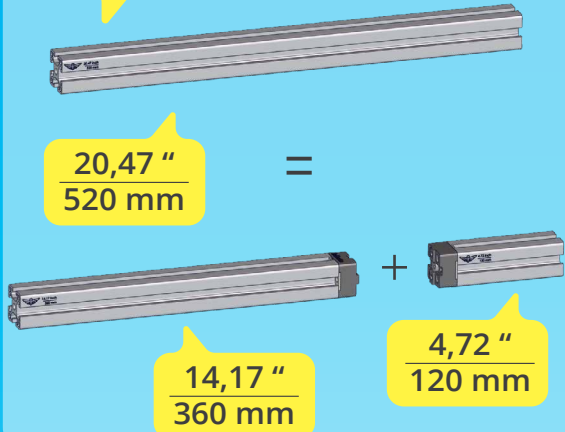



20,47 "  
520 mm

Add a small droplet of threadlock to secure the bolts

✓

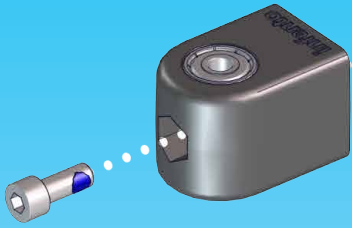
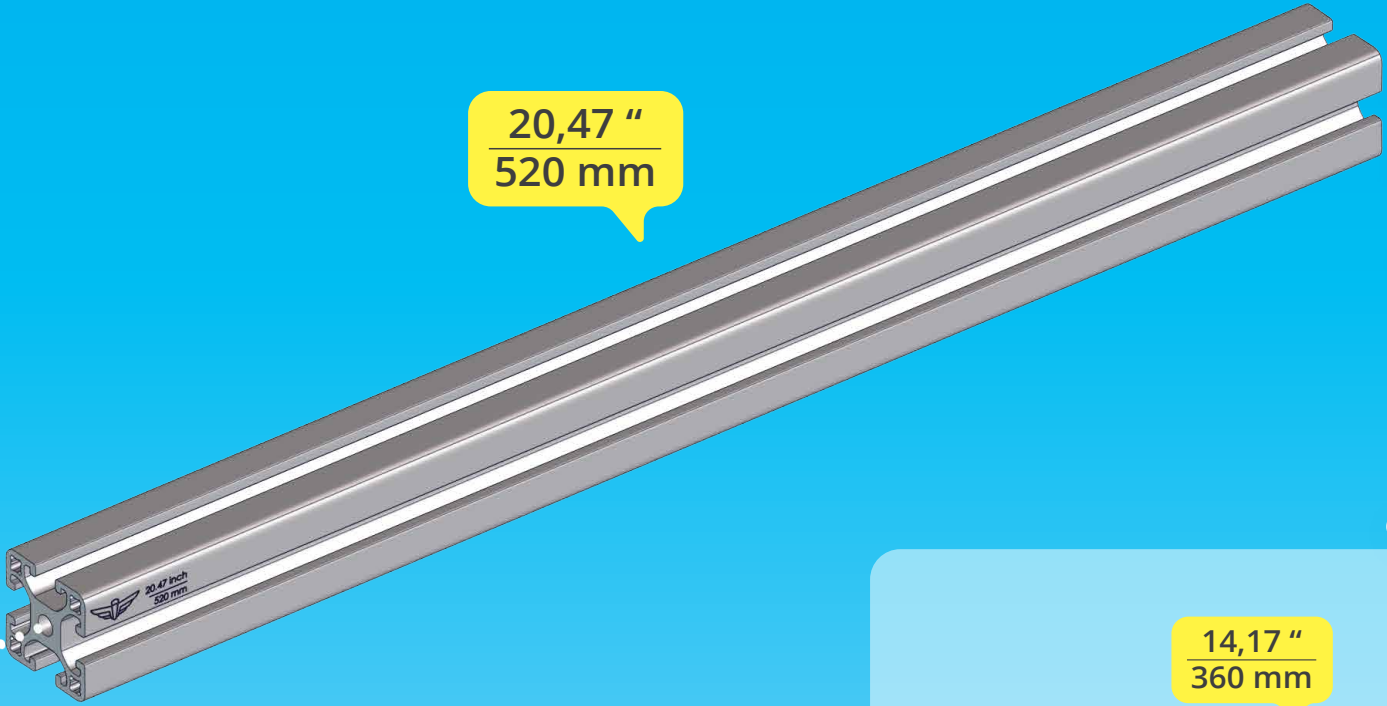
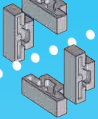

M8x20

4,72 "  
120 mm

14,17 "  
360 mm



C.3



10,00 "  
254 mm

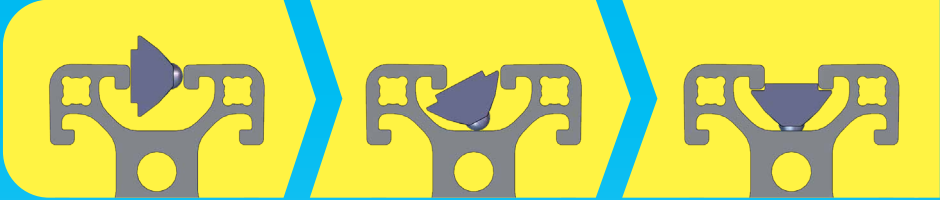
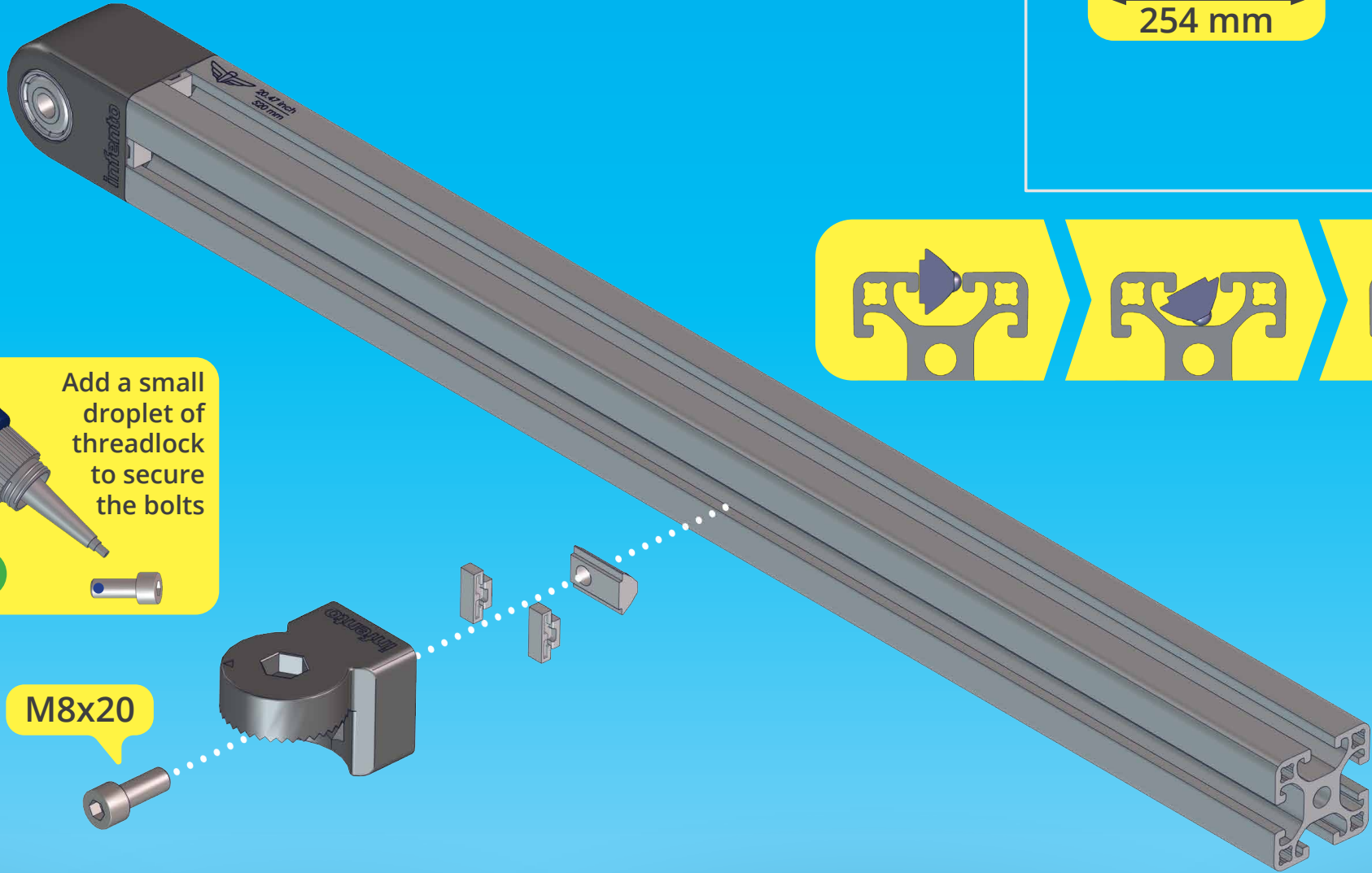

Add a small droplet of threadlock to secure the bolts

M8x20



Add a small droplet of threadlock to secure the bolts

M8x20

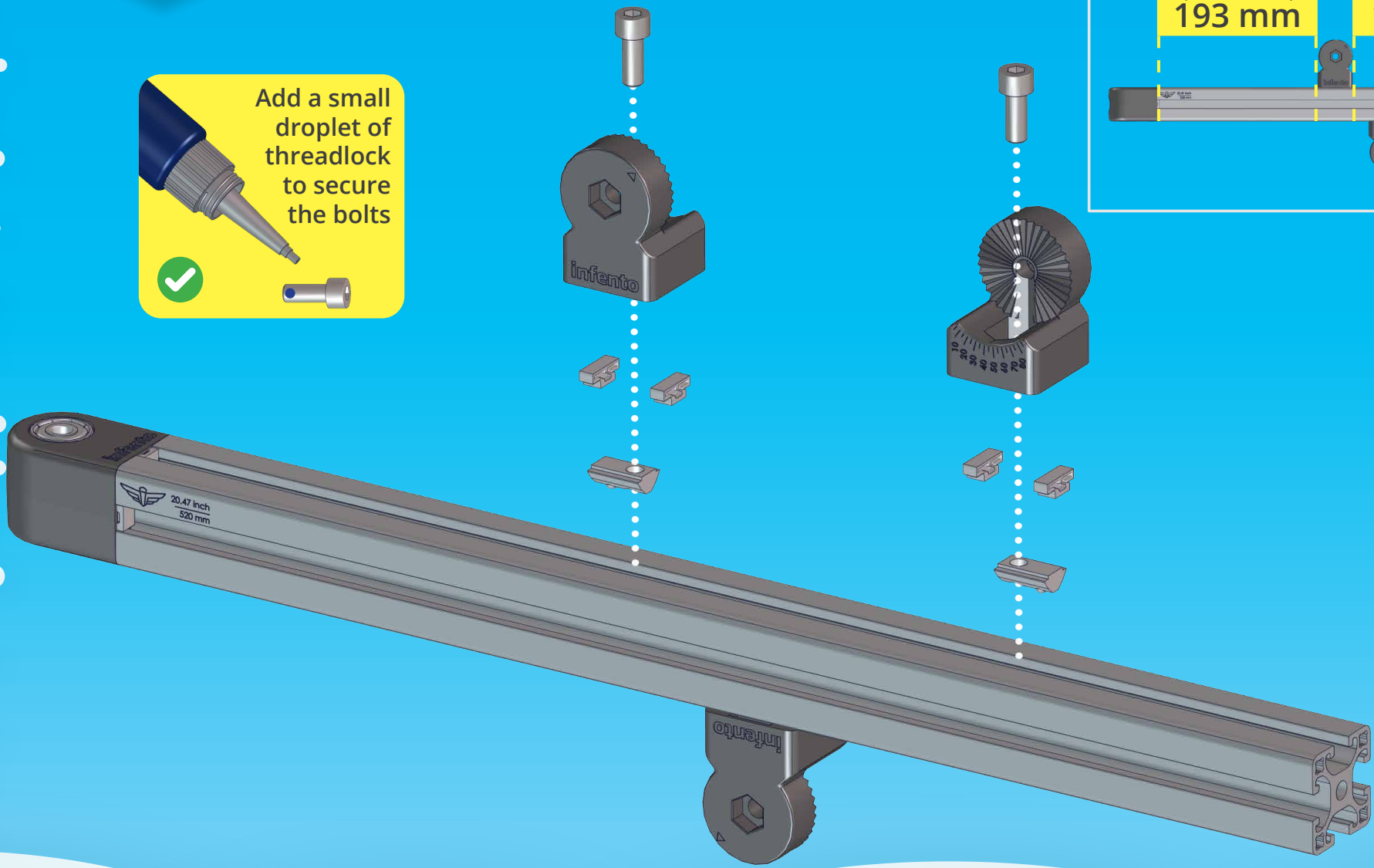
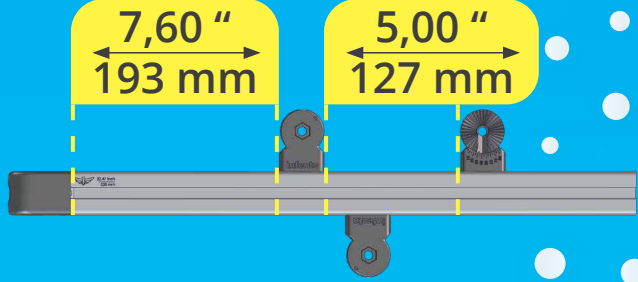



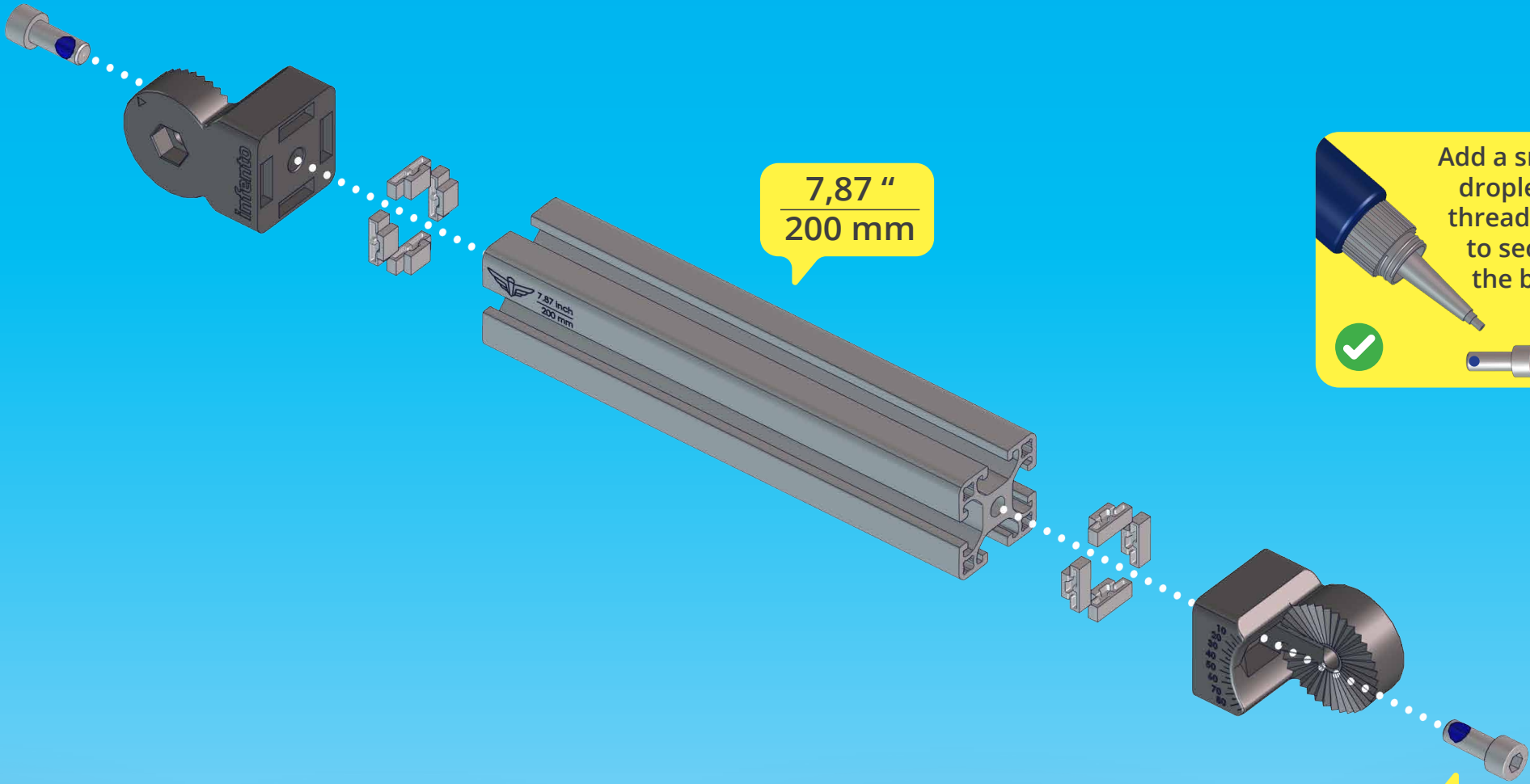

7,87 "  
200 mm

Add a small droplet of threadlock to secure the bolts

M8x20



M8  
LOCKNUT

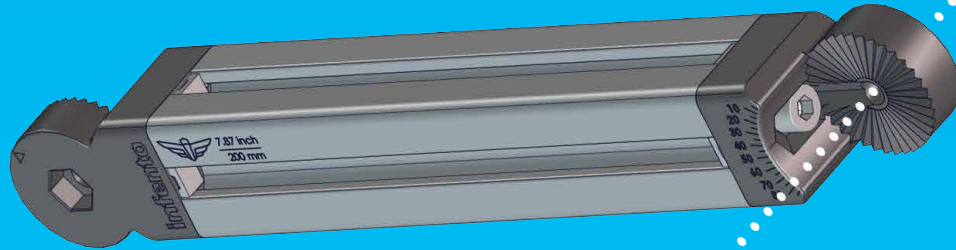

Knurled disc  
2 STRIPES

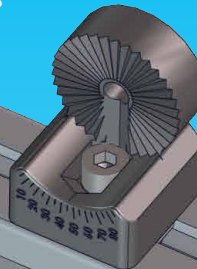
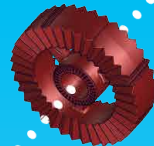

M8x35

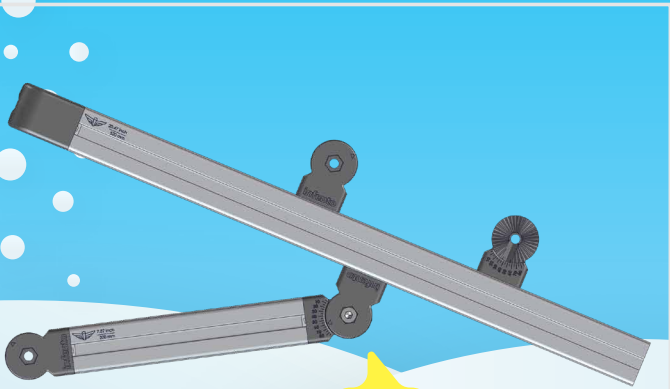

60°



M8x20  
LOW HEAD

3,15 "  
80 mm

Add a small droplet of threadlock to secure the bolts

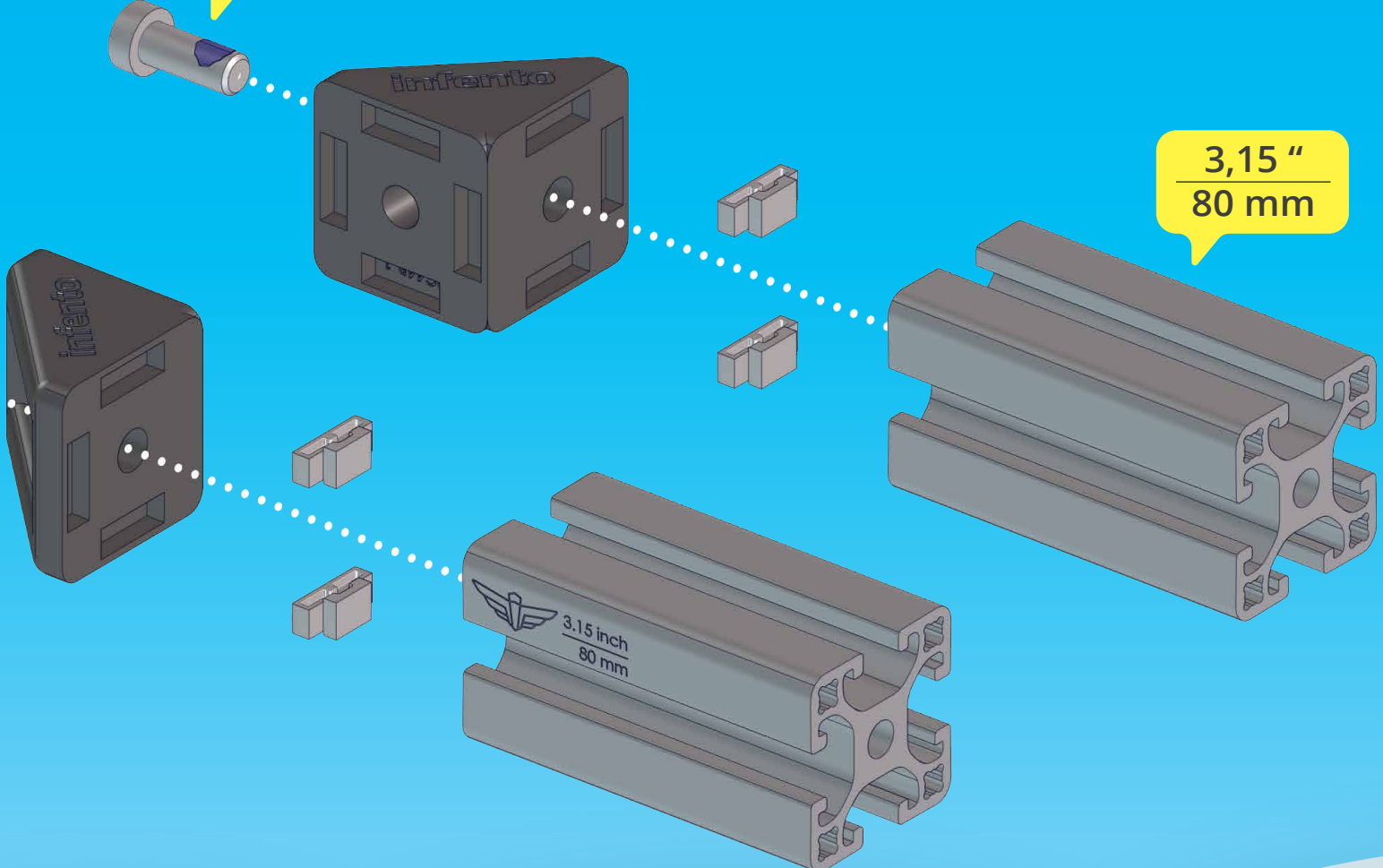

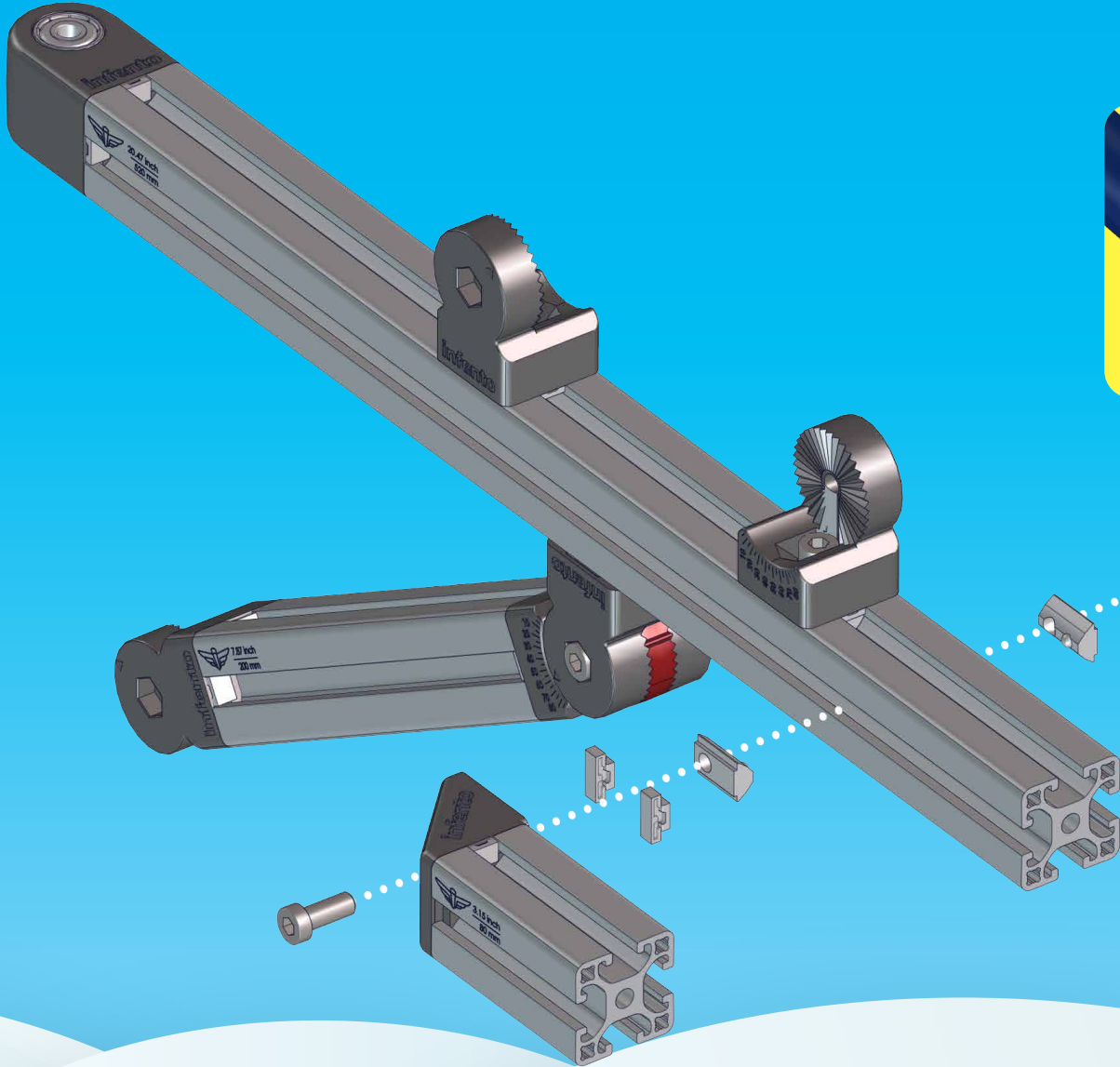

Add a small droplet of threadlock to secure the bolts

M8x20  
LOW HEAD

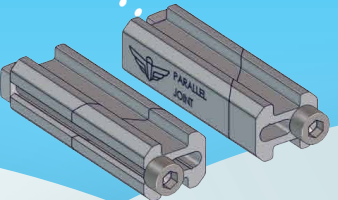
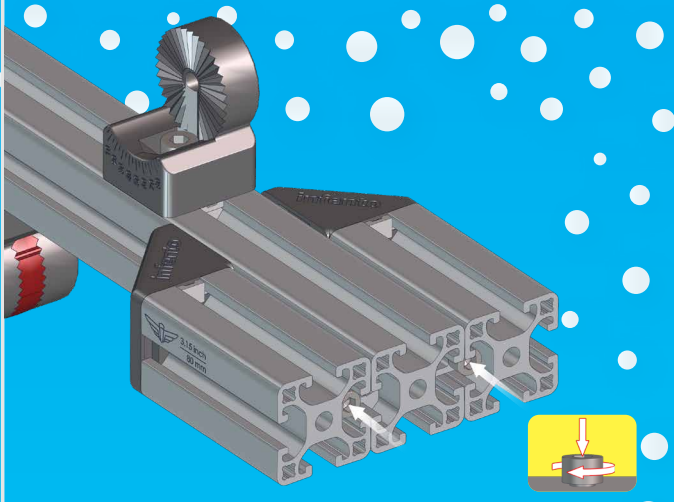
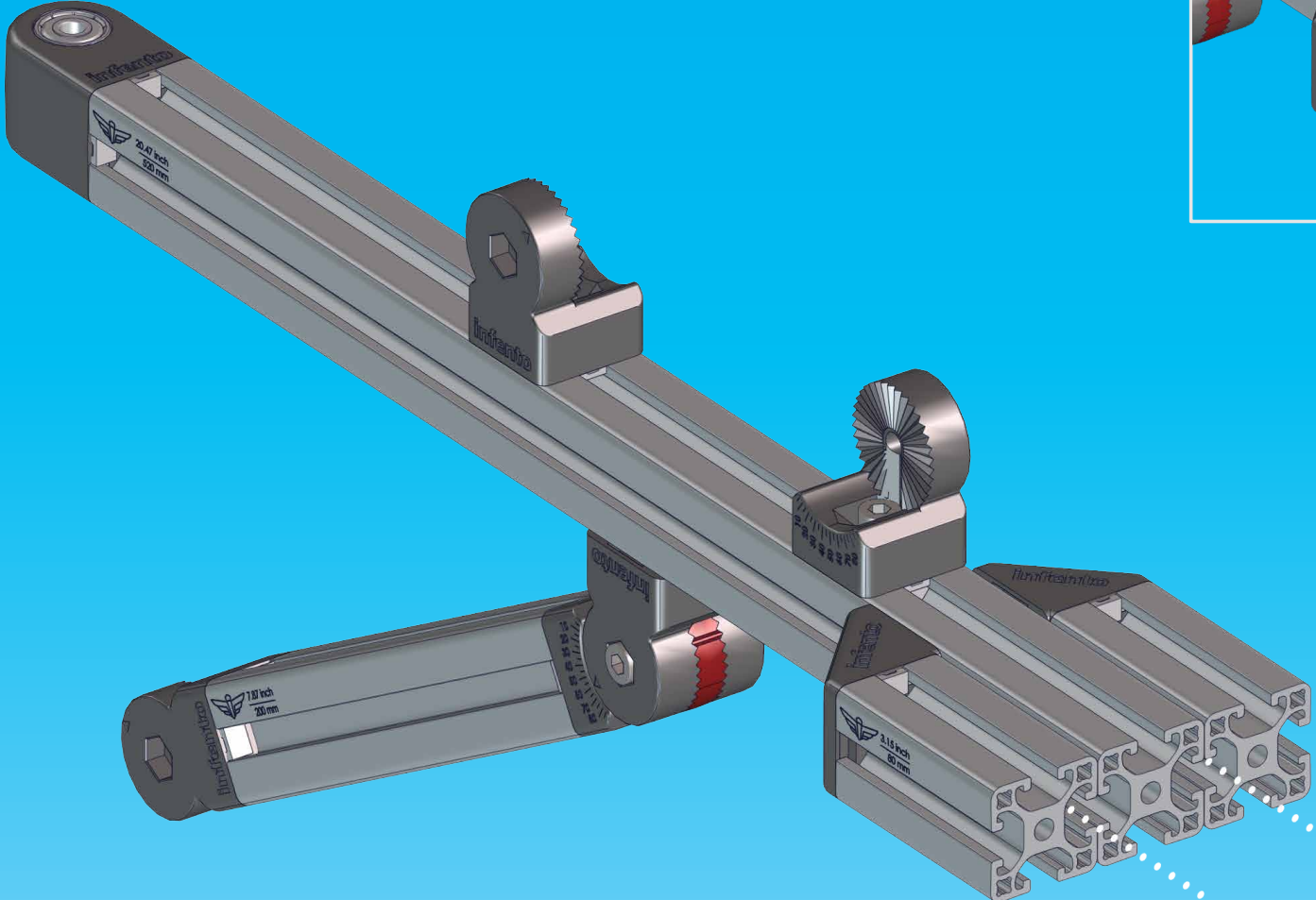



C.10

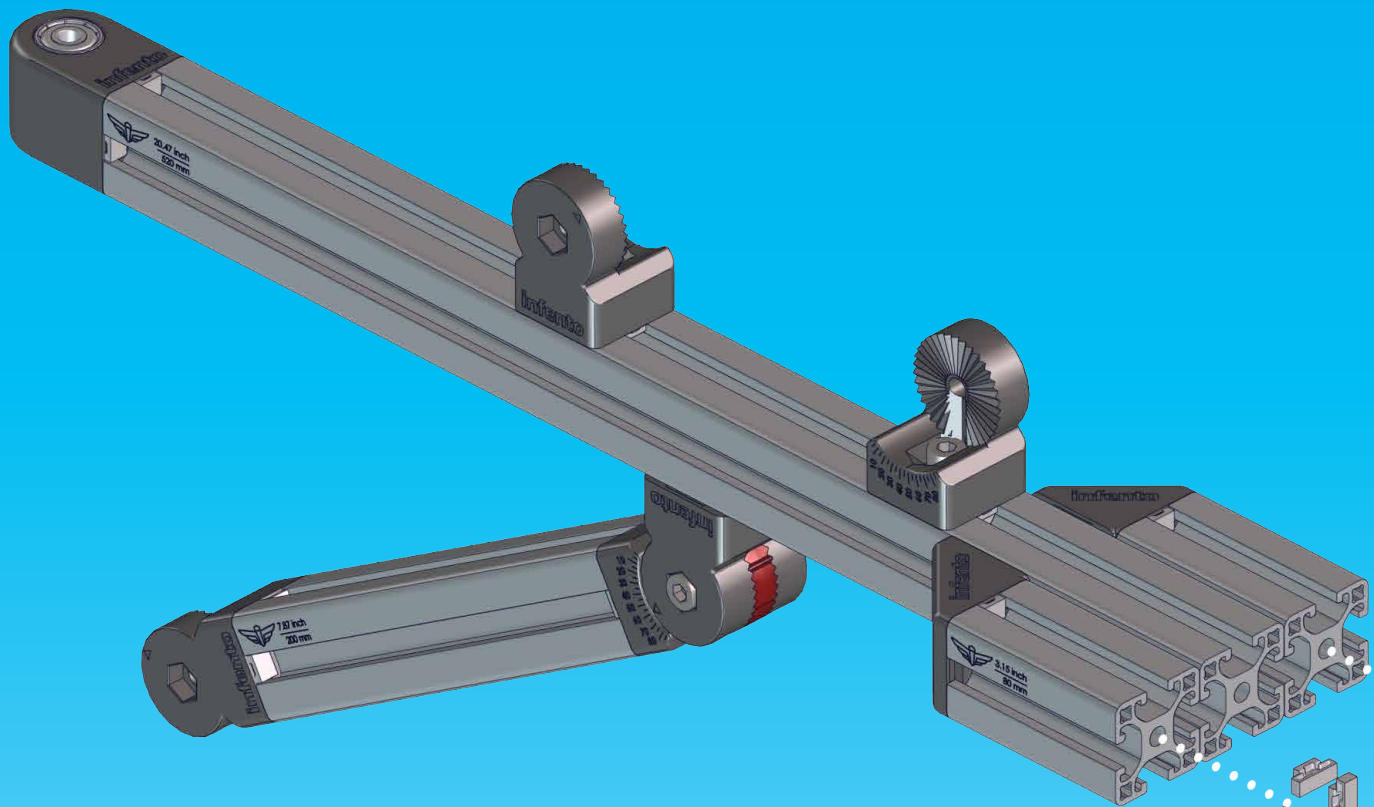

Add a small droplet of threadlock to secure the bolts

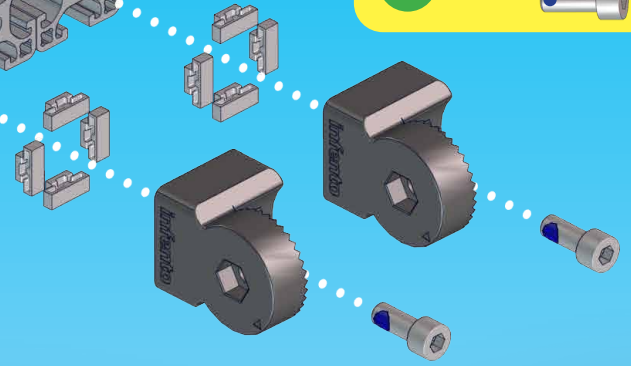

M8x20



C.11

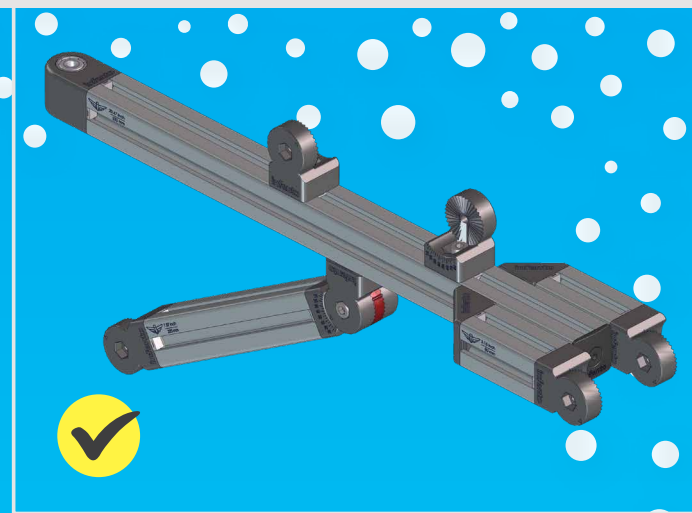
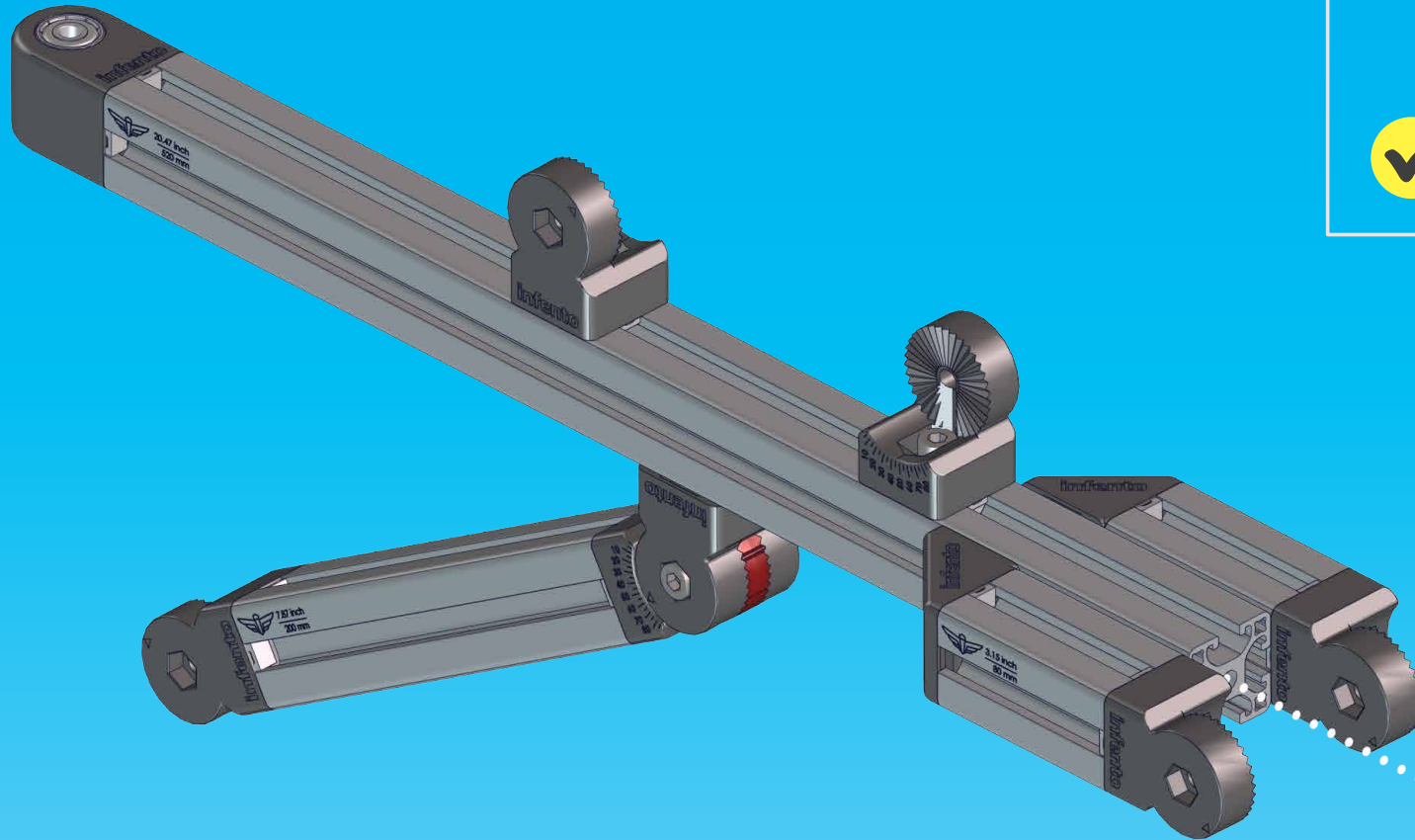

Add a small droplet of threadlock to secure the bolts



M8x12  
COUNTERSUNK





# D.1

1

If you don't have this profile in your kit, make one using the following steps

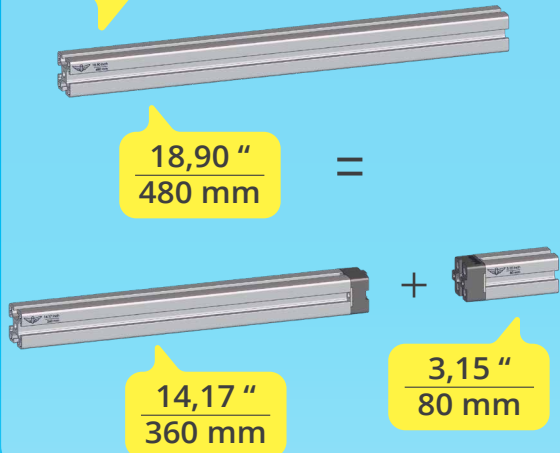

2

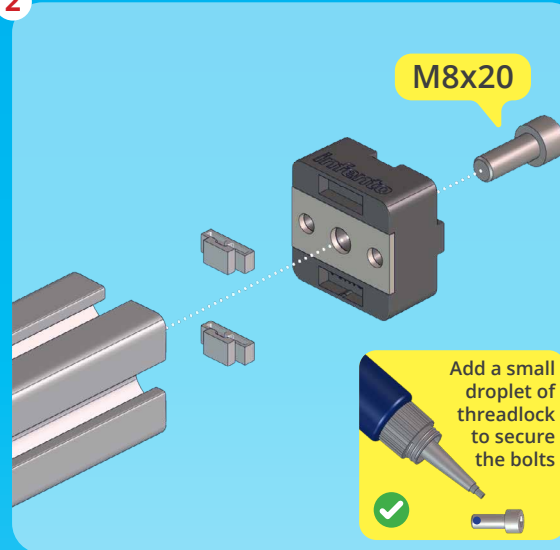

3

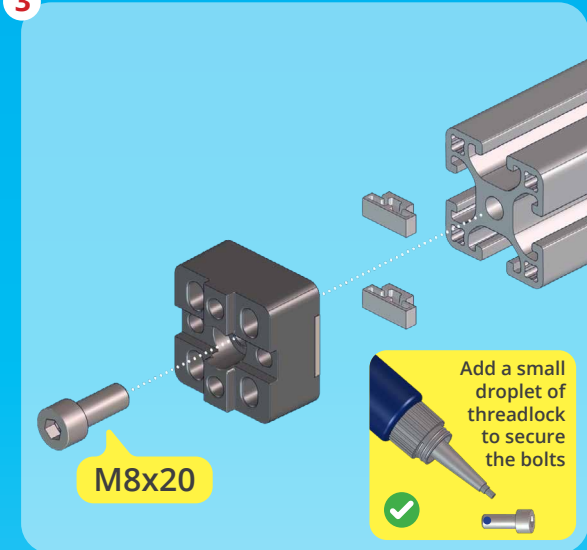

4

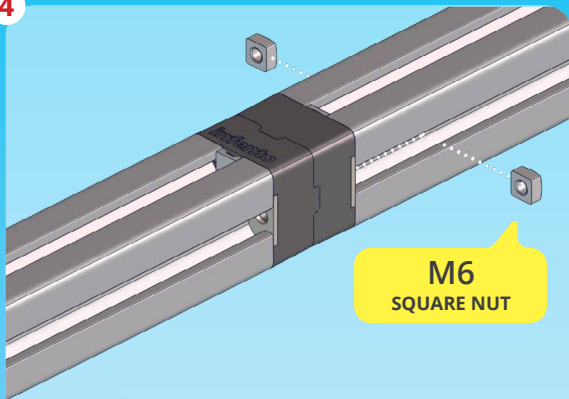

5



6







**D.2**

M8x20

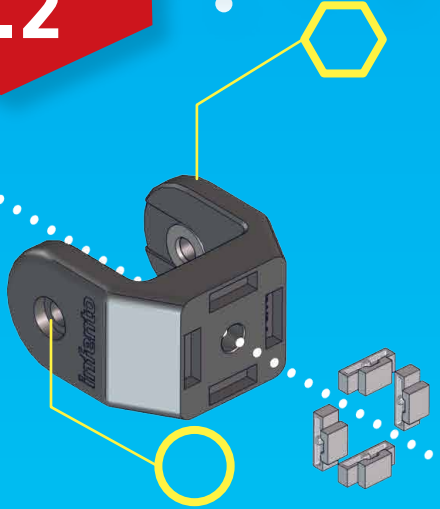

Don't disassemble.  
You can leave  
them in.

If you don't have nock washers,  
use M8-16 washers instead.



Add a small  
droplet of  
threadlock  
to secure  
the bolts



14,17 "  
360 mm

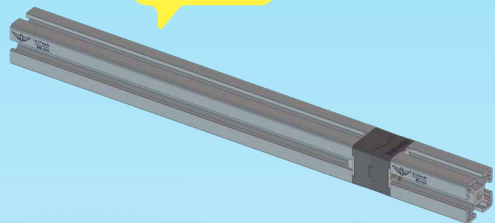

3,15 "  
80 mm

18,90 "  
480 mm



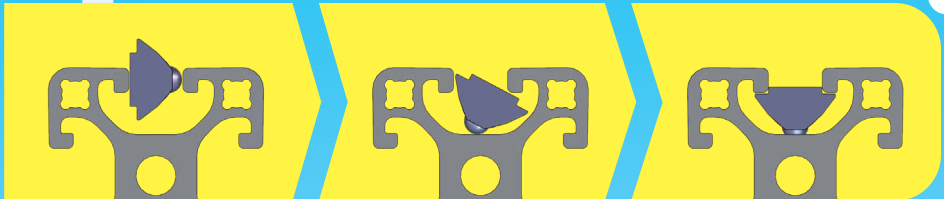
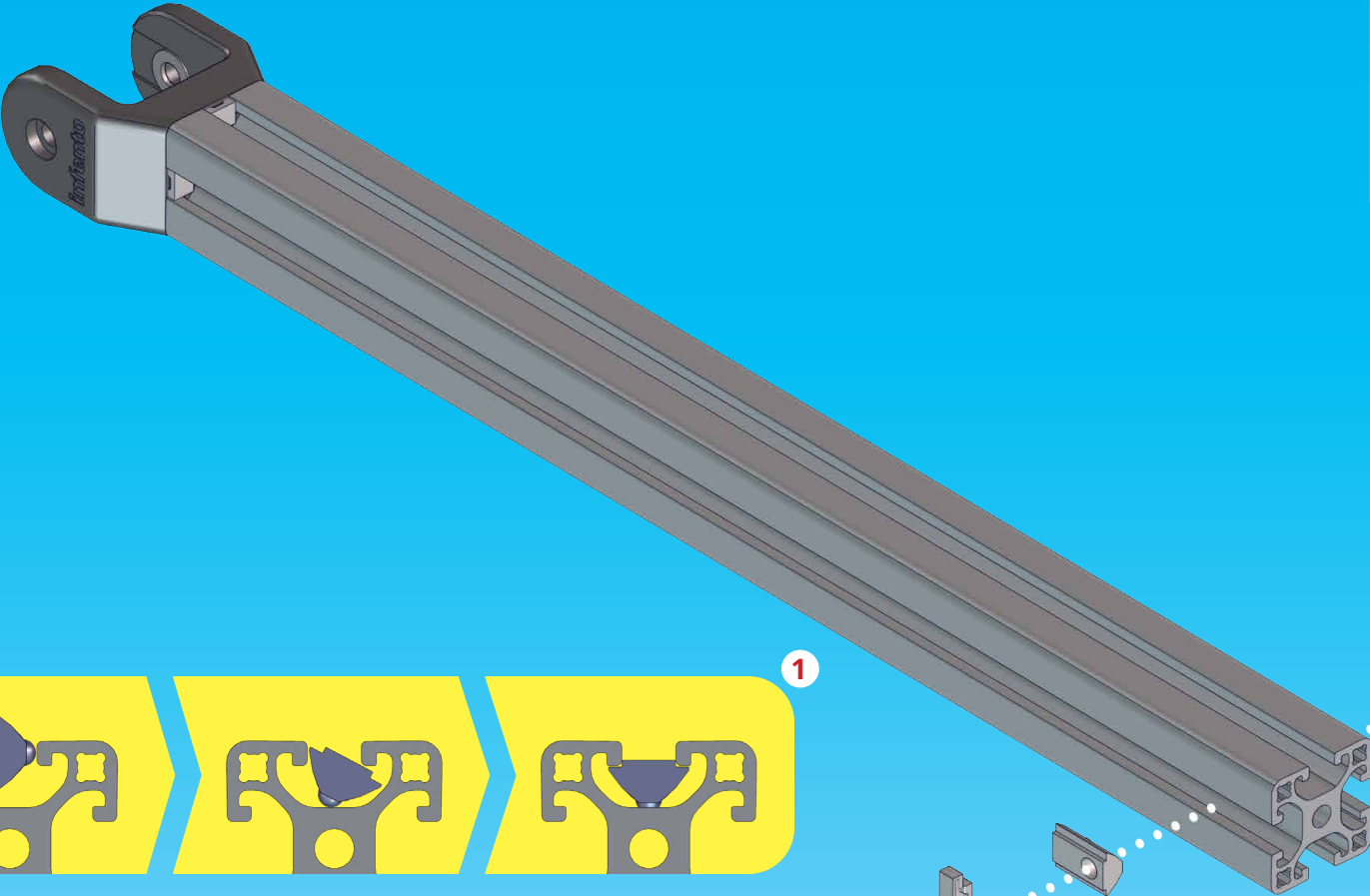
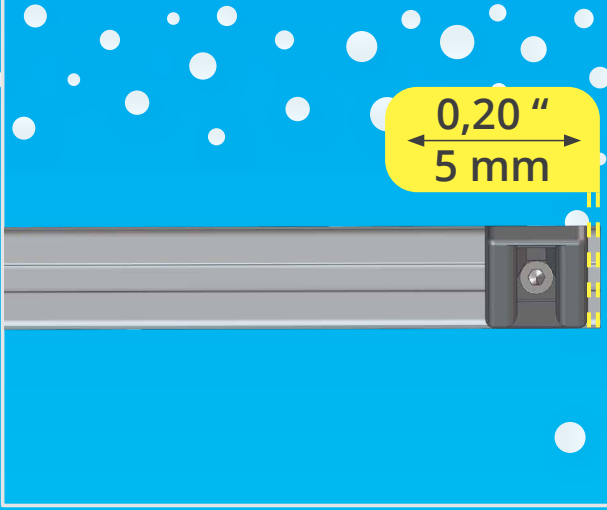

**M8x20  
LOW HEAD**

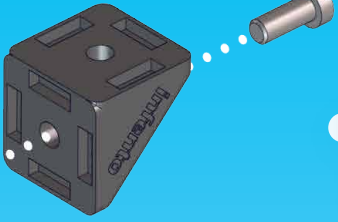

Add a small droplet of threadlock to secure the bolts



D.4

M8x25  
LOW HEAD

Add a small  
droplet of  
threadlock  
to secure  
the bolts

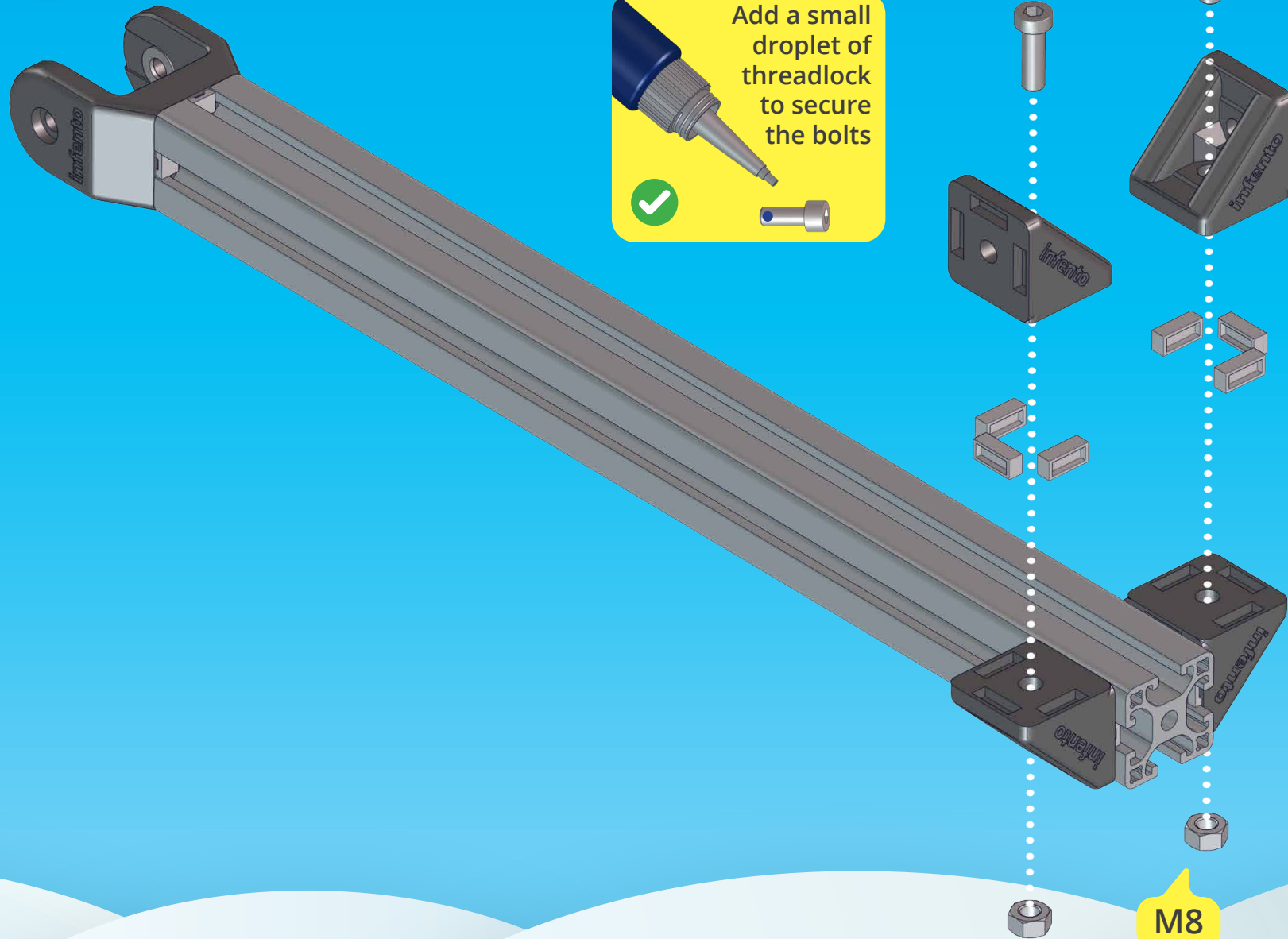

M8

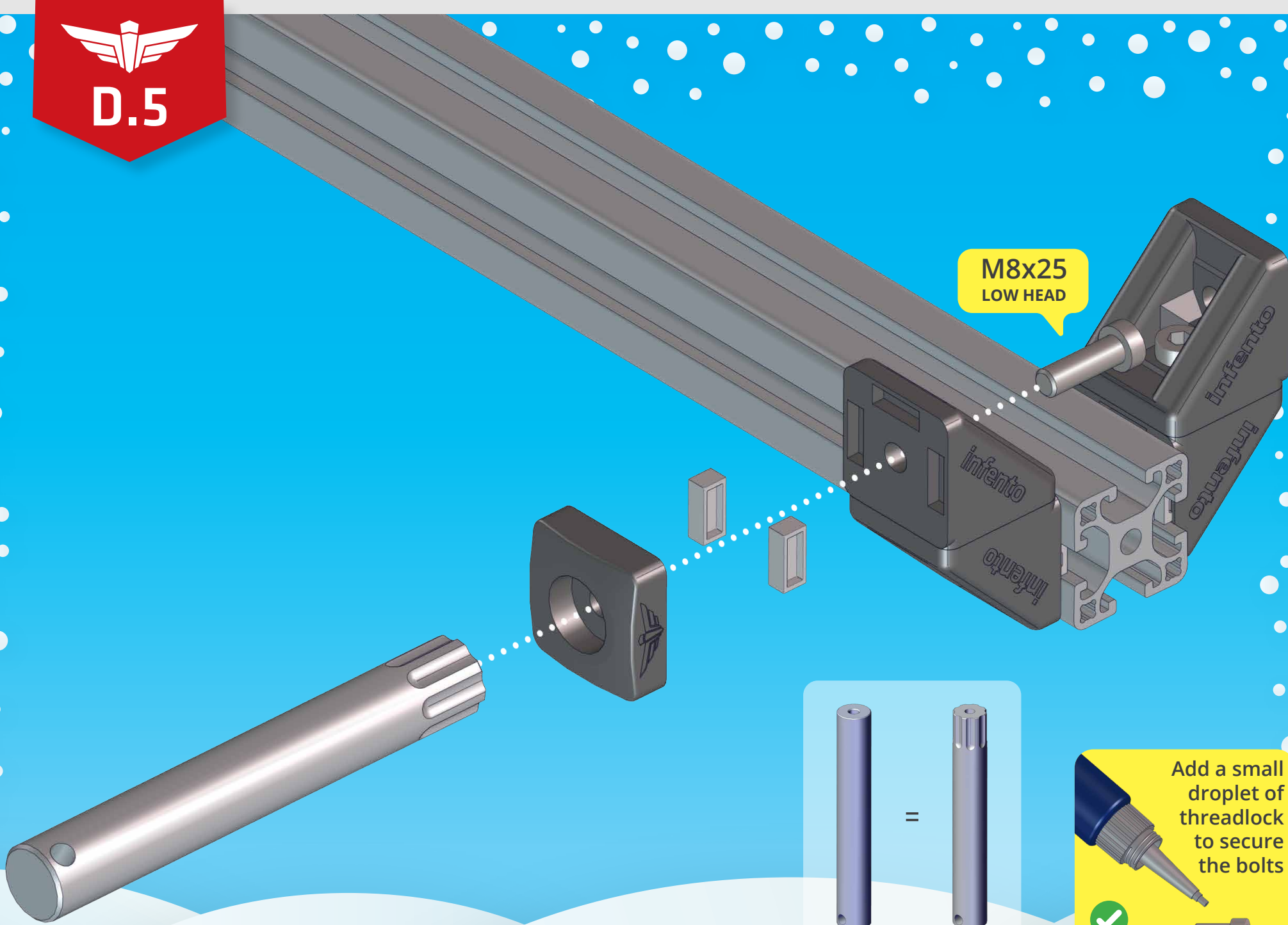

M8x25  
LOW HEAD



Add a small droplet of threadlock to secure the bolts





D.6

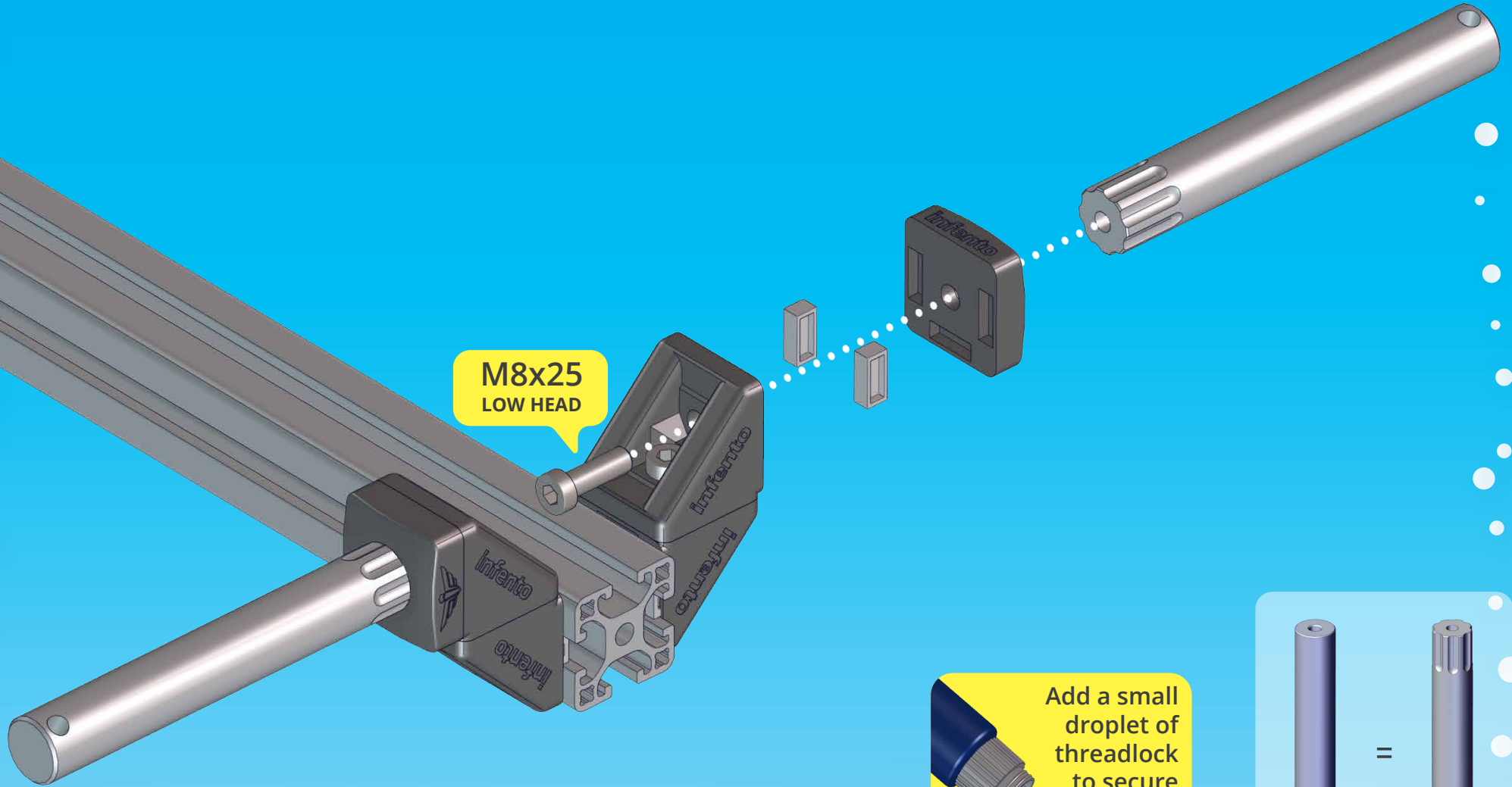

M8x25  
LOW HEAD



Add a small  
droplet of  
threadlock  
to secure  
the bolts



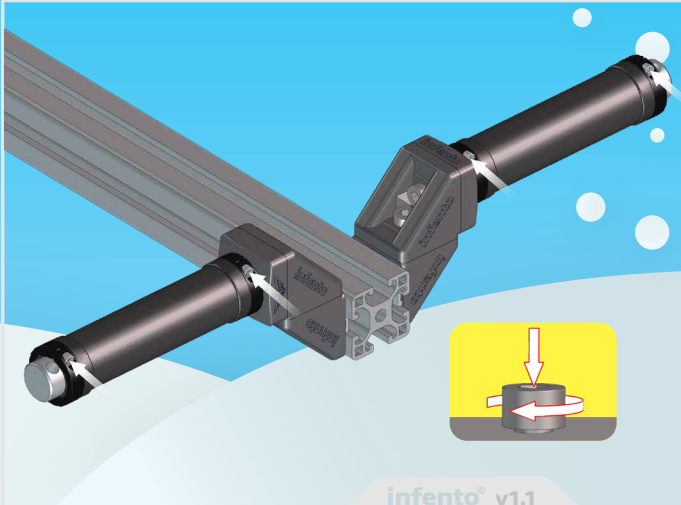
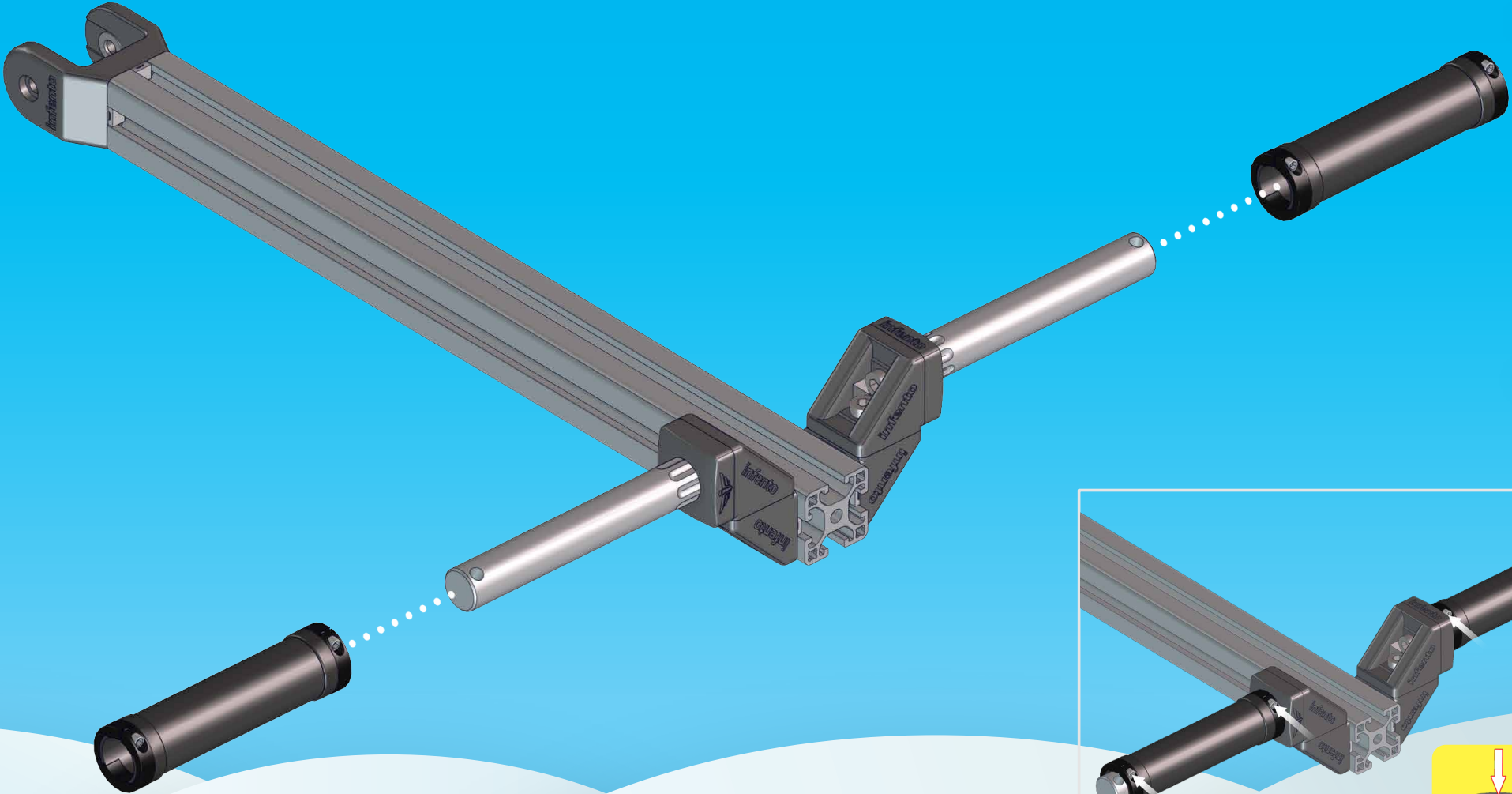

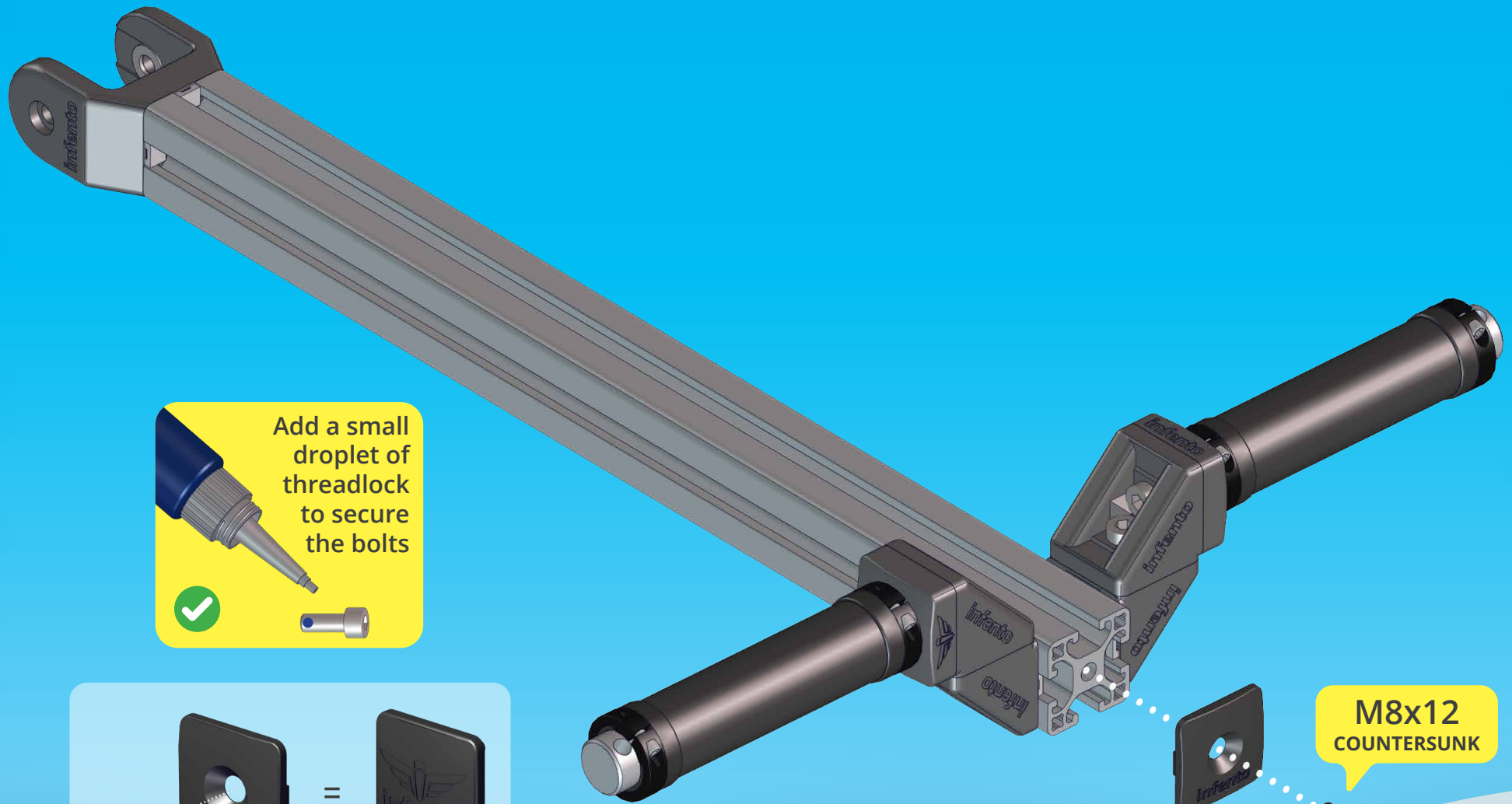

Add a small droplet of threadlock to secure the bolts



**M8x12  
COUNTERSUNK**

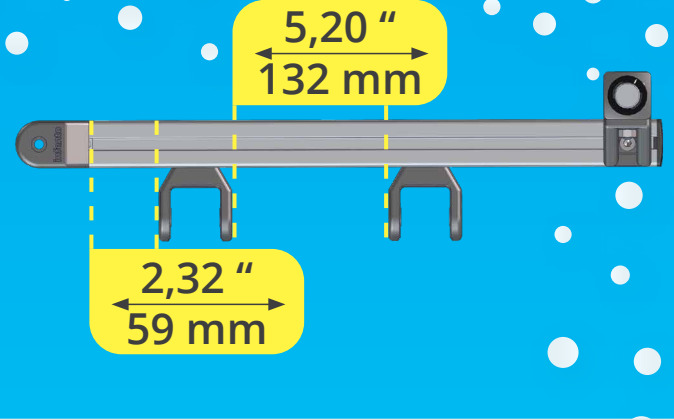

If you don't have nock washers, use M8-16 washers instead.

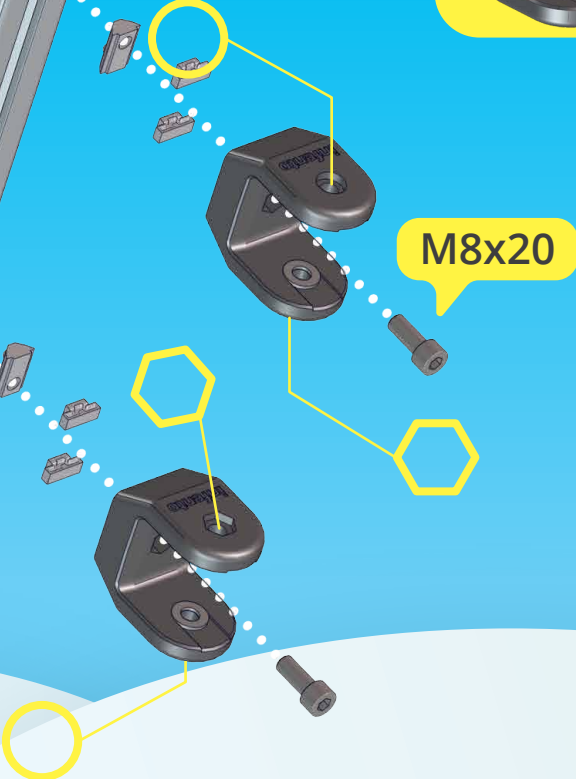





D.10

$\frac{5,12''}{130 \text{ mm}}$  /  $\frac{4,65''}{118 \text{ mm}}$

2x



Add a small droplet of threadlock to secure the bolts



M8x35  
ADJUSTING BOLT

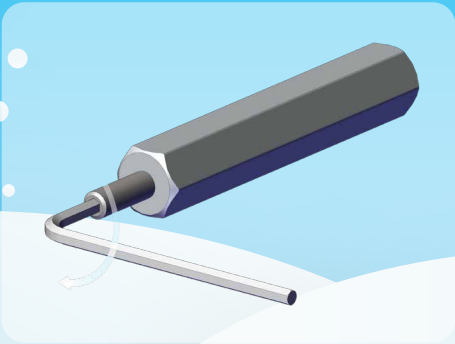



D.11

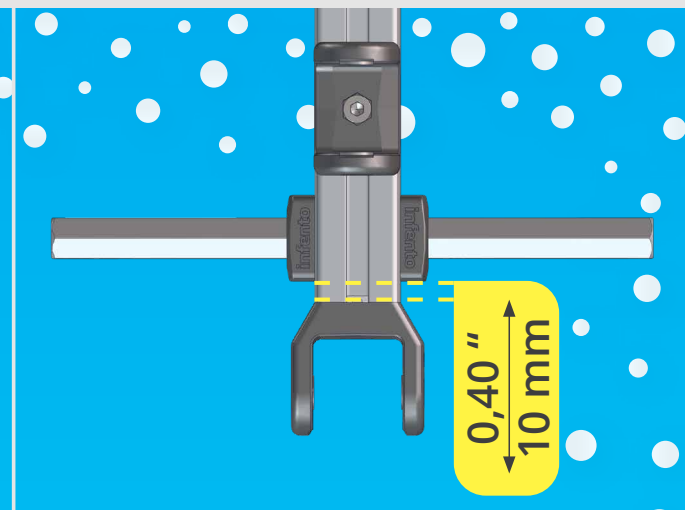
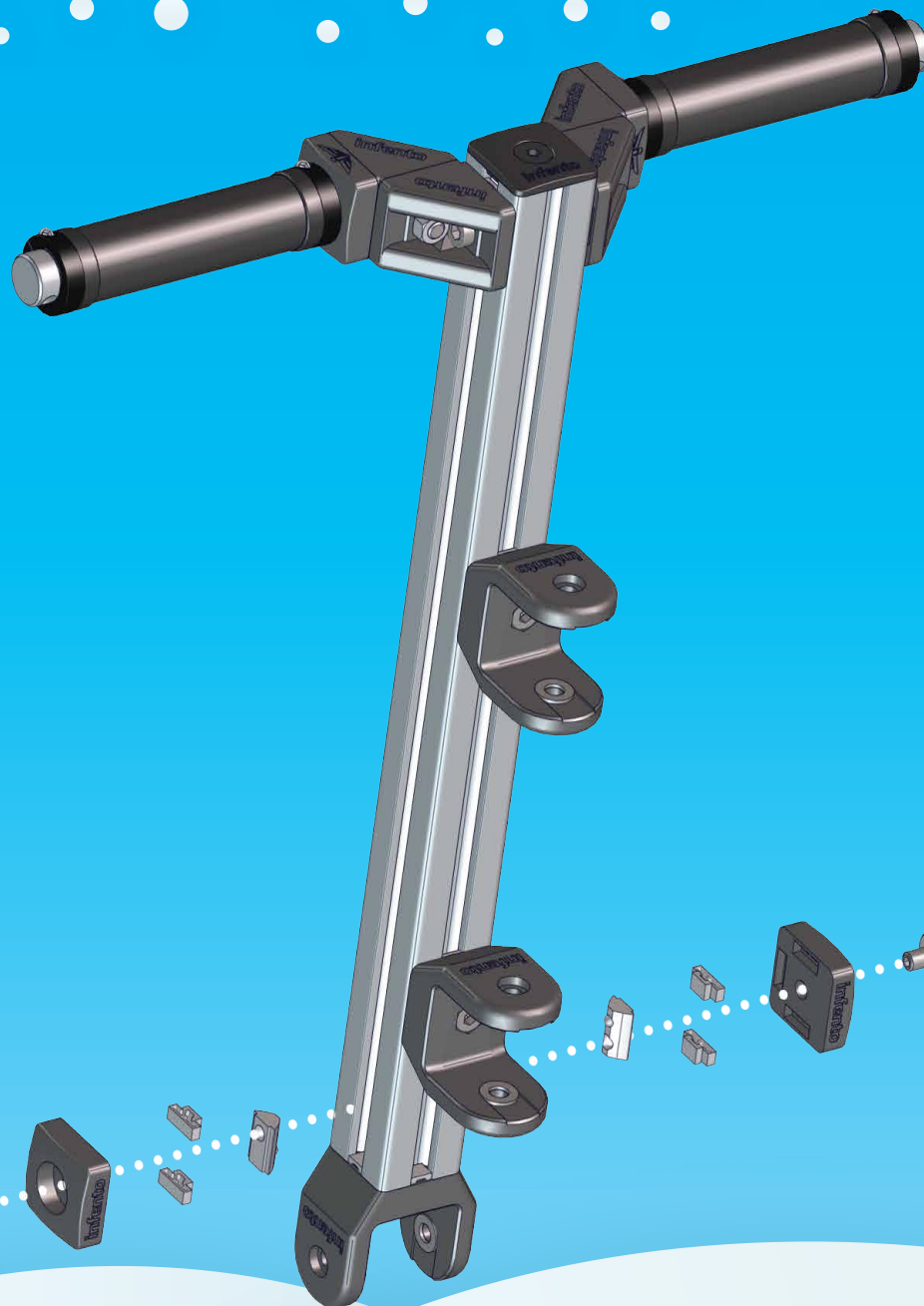

Add a small droplet of threadlock to secure the bolts

M8x25

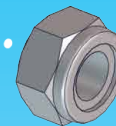
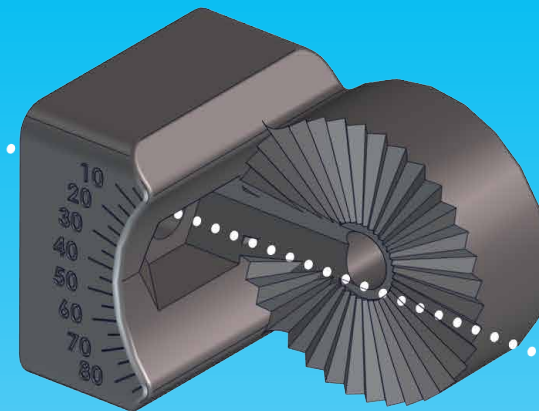
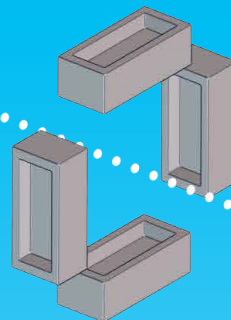
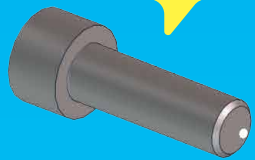

M8  
LOCKNUT



D.13

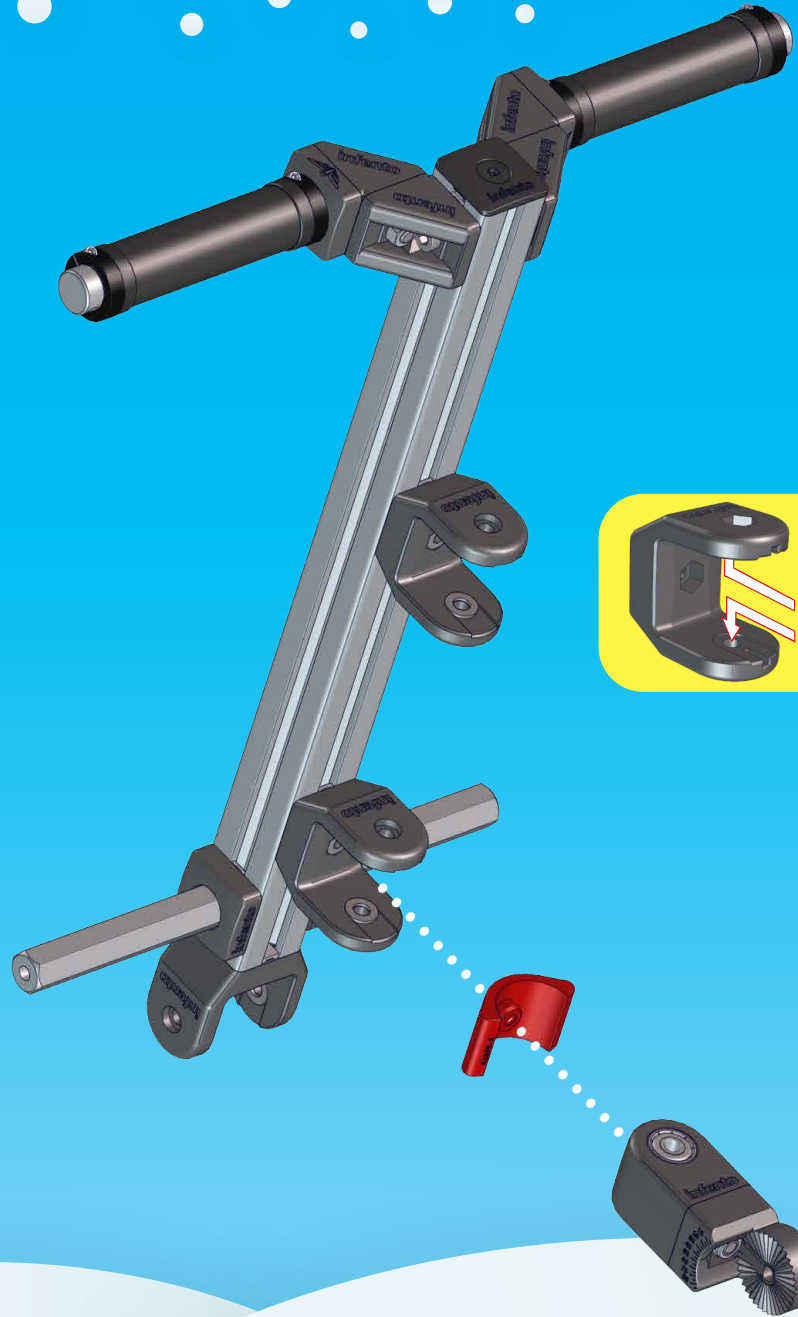

Don't disassemble.  
You can leave  
them in.

If you don't have nock washers,  
use M8-16 washers instead.



D.14



M8x60

M8  
LOCKNUT



5,51 "  
140 mm



Add a small droplet of threadlock to secure the bolts

✓

M8x20

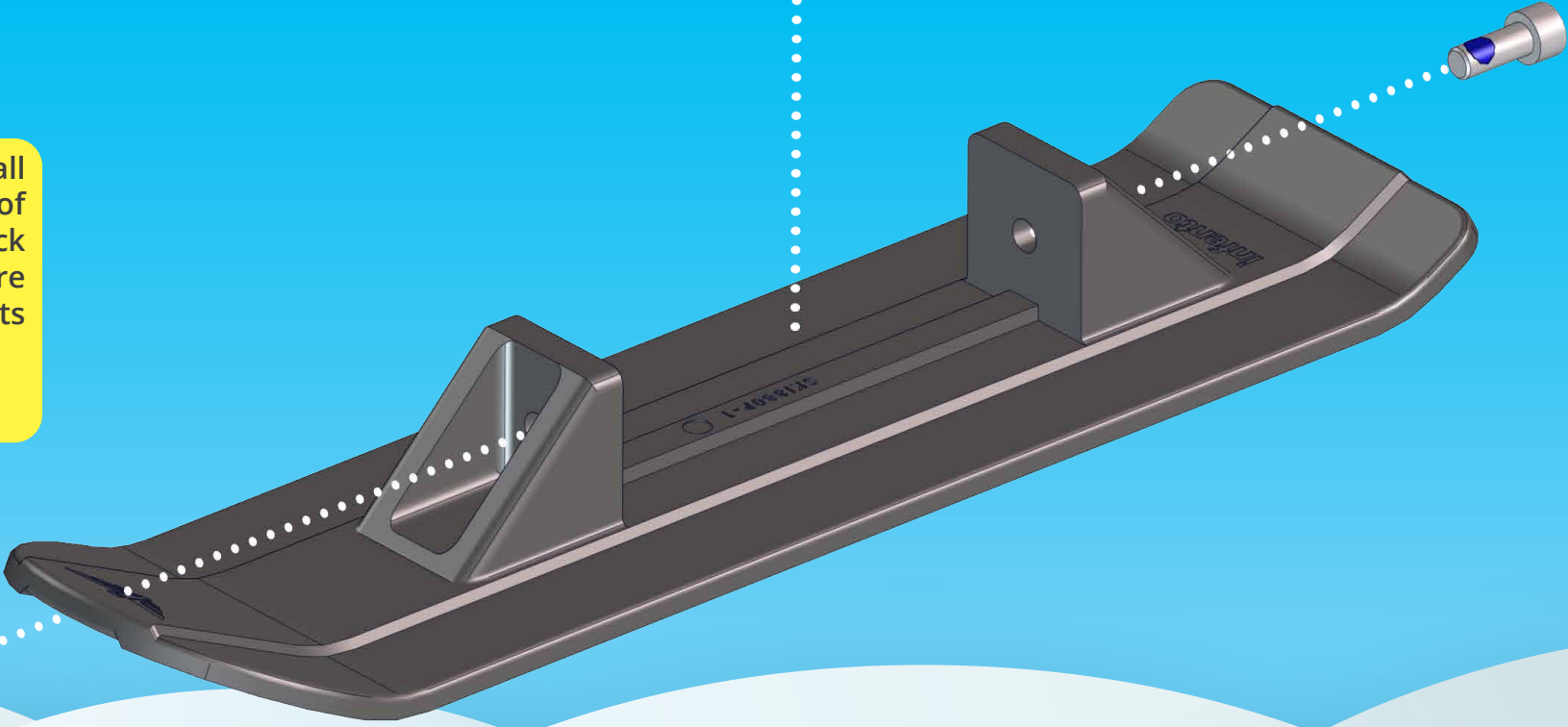
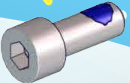

  
**D.16**

M8x20

Add a small droplet of threadlock to secure the bolts

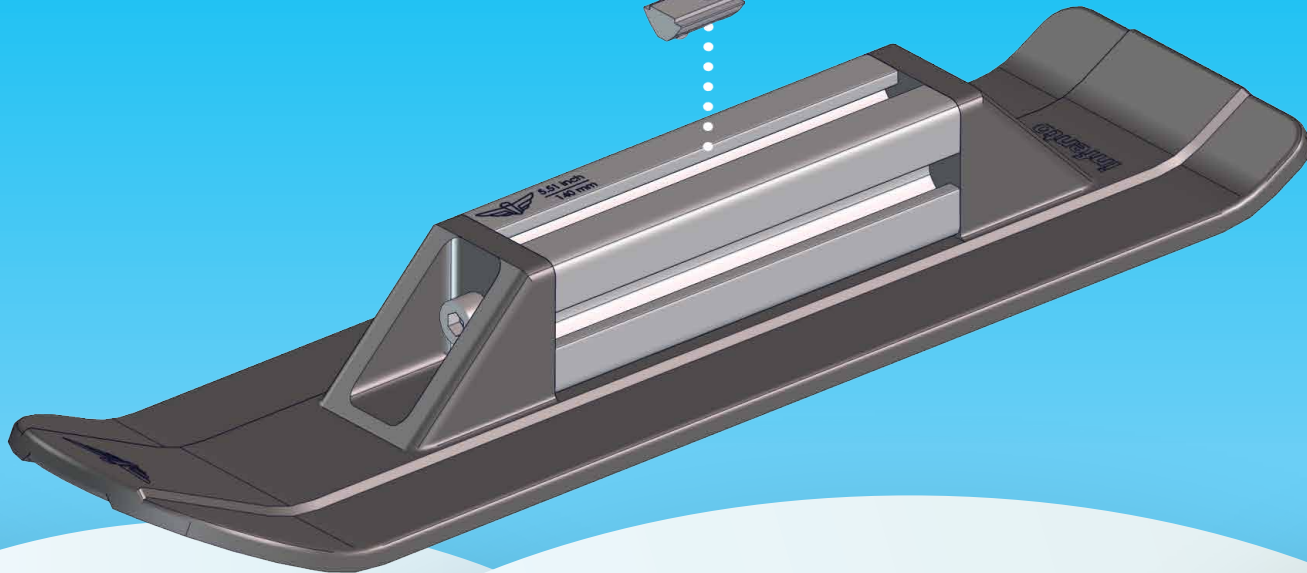
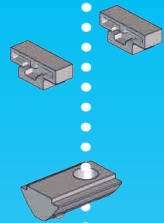
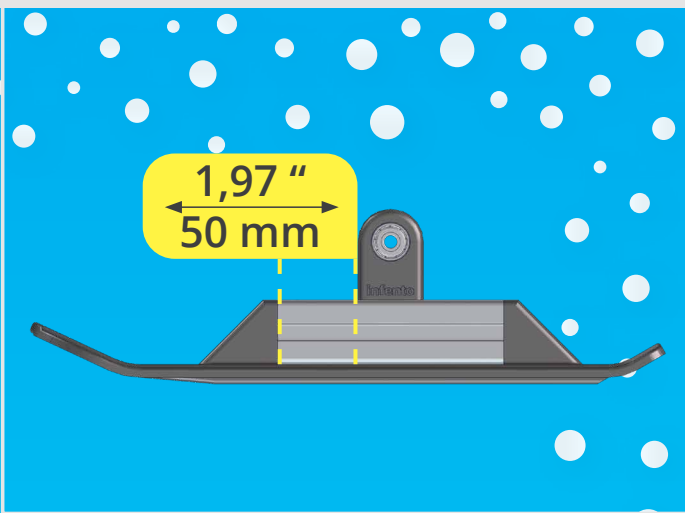



D.17

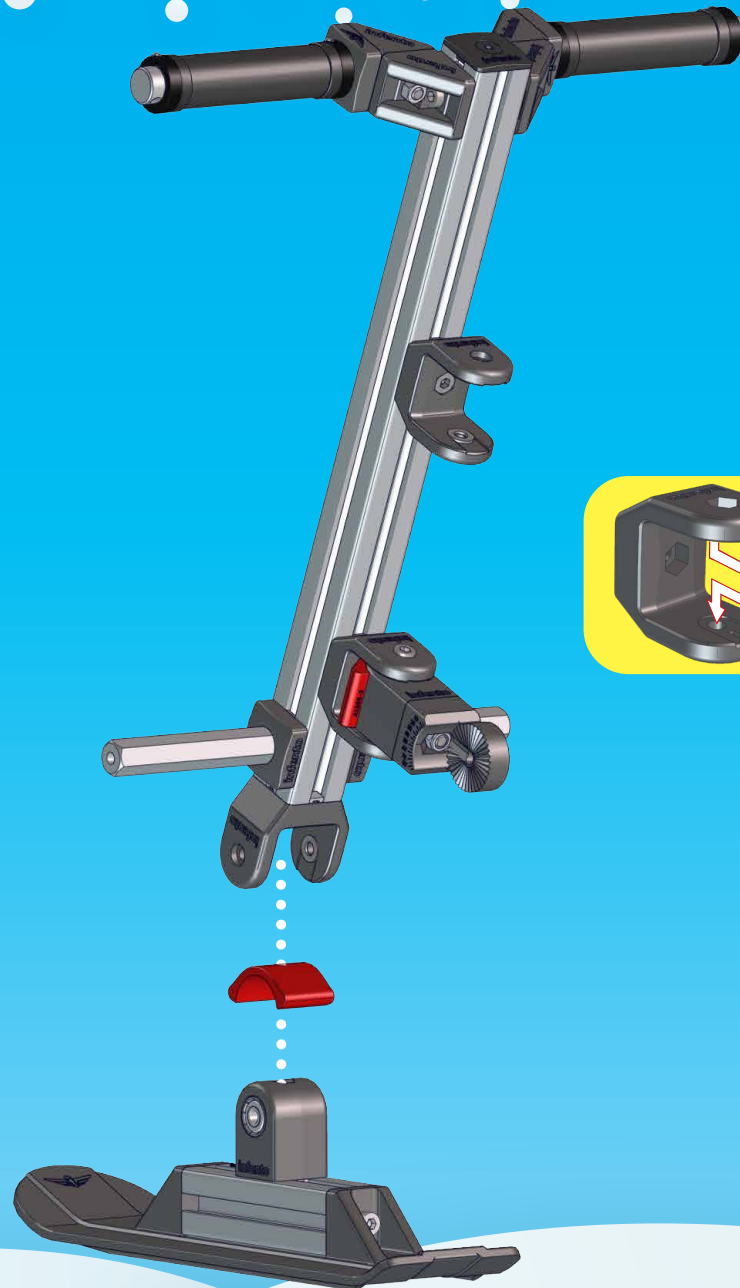

Don't disassemble.  
You can leave  
them in.

If you don't have nock washers,  
use M8-16 washers instead.





D.18



M8x60

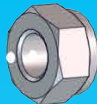

M8  
LOCKNUT

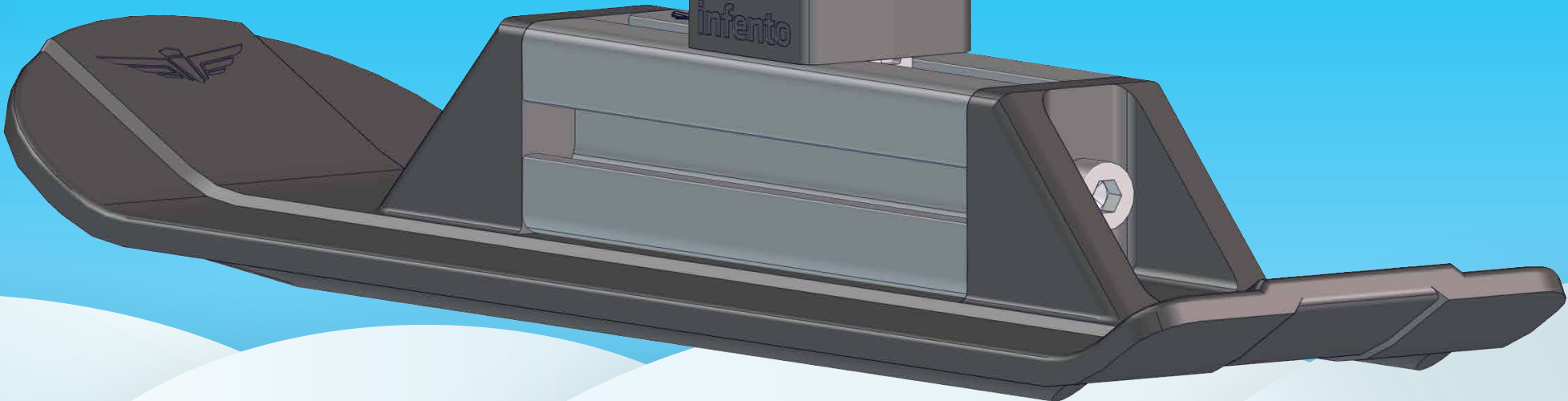



D.19

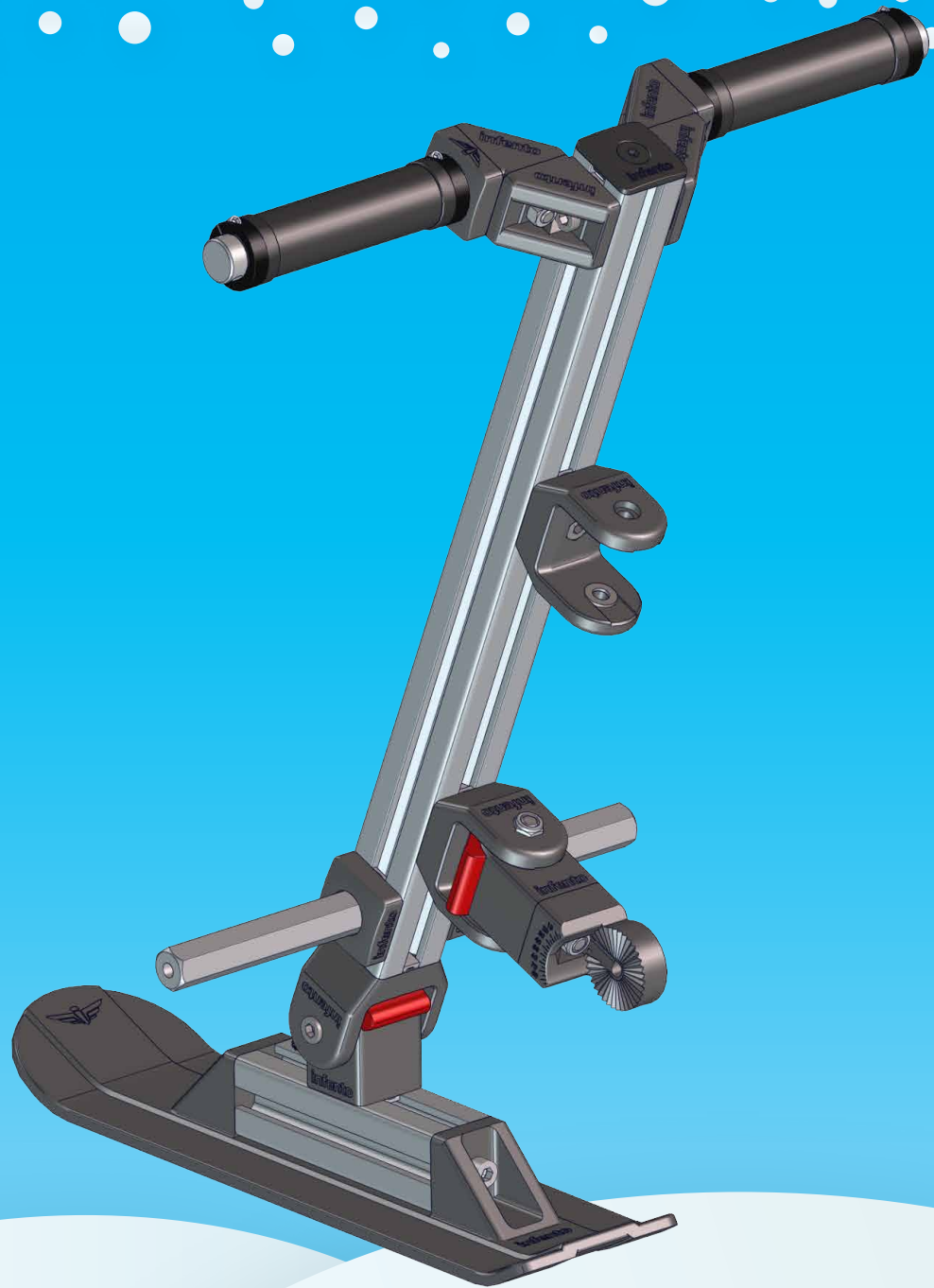

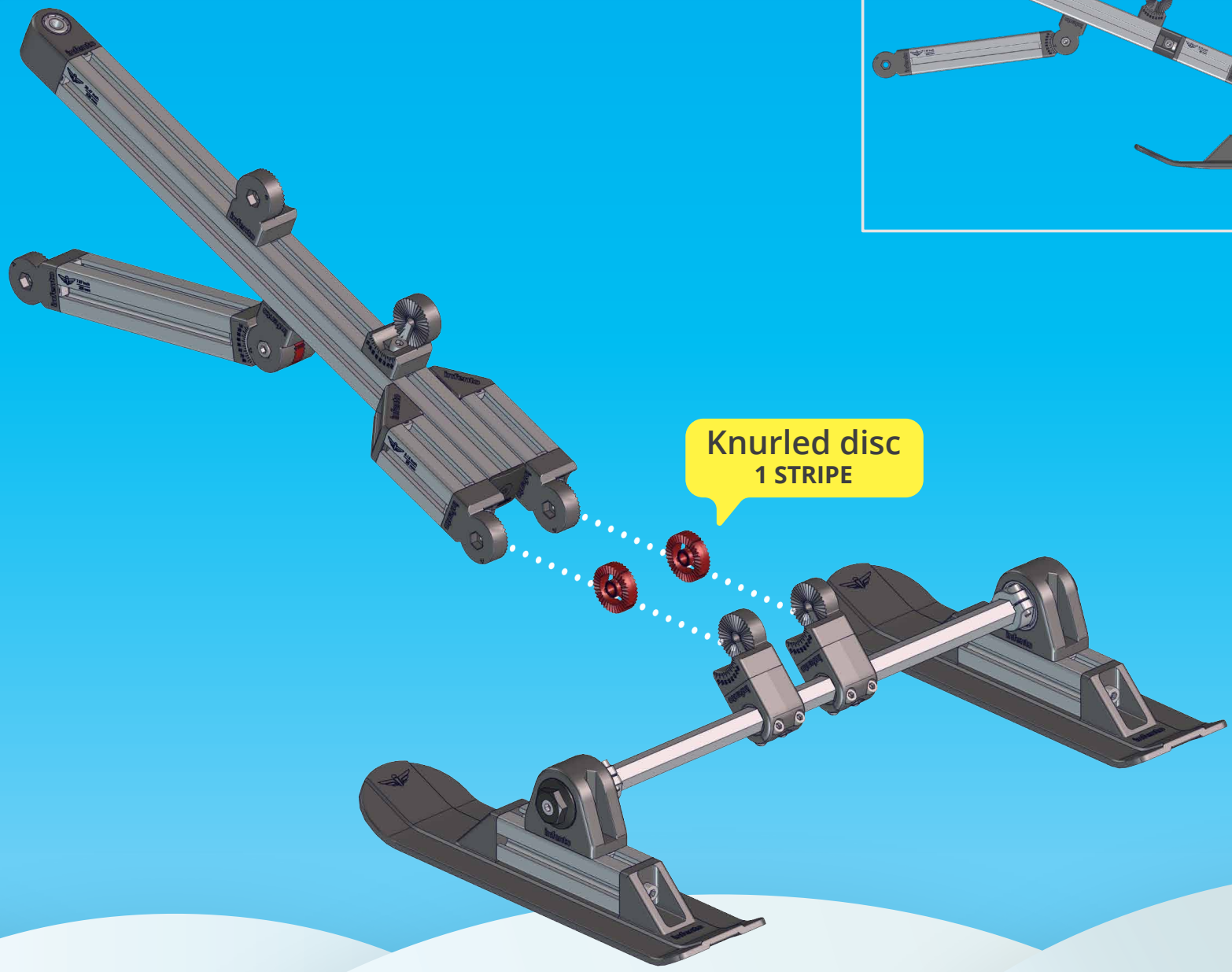

Knurled disc  
1 STRIPE

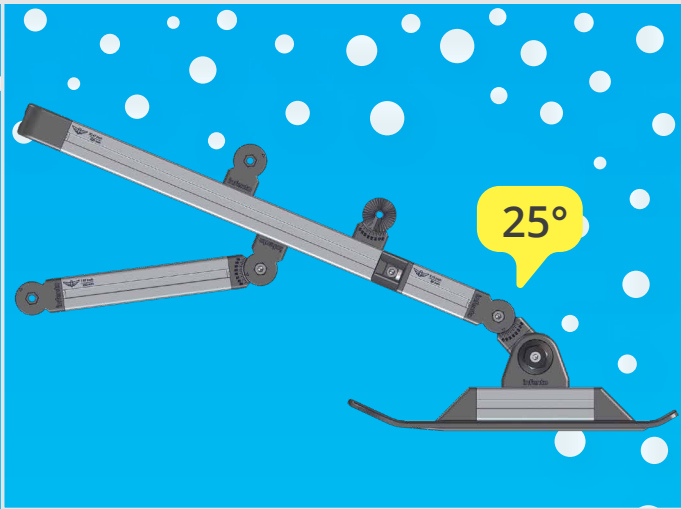



E.2

M8x35

M8  
LOCKNUT

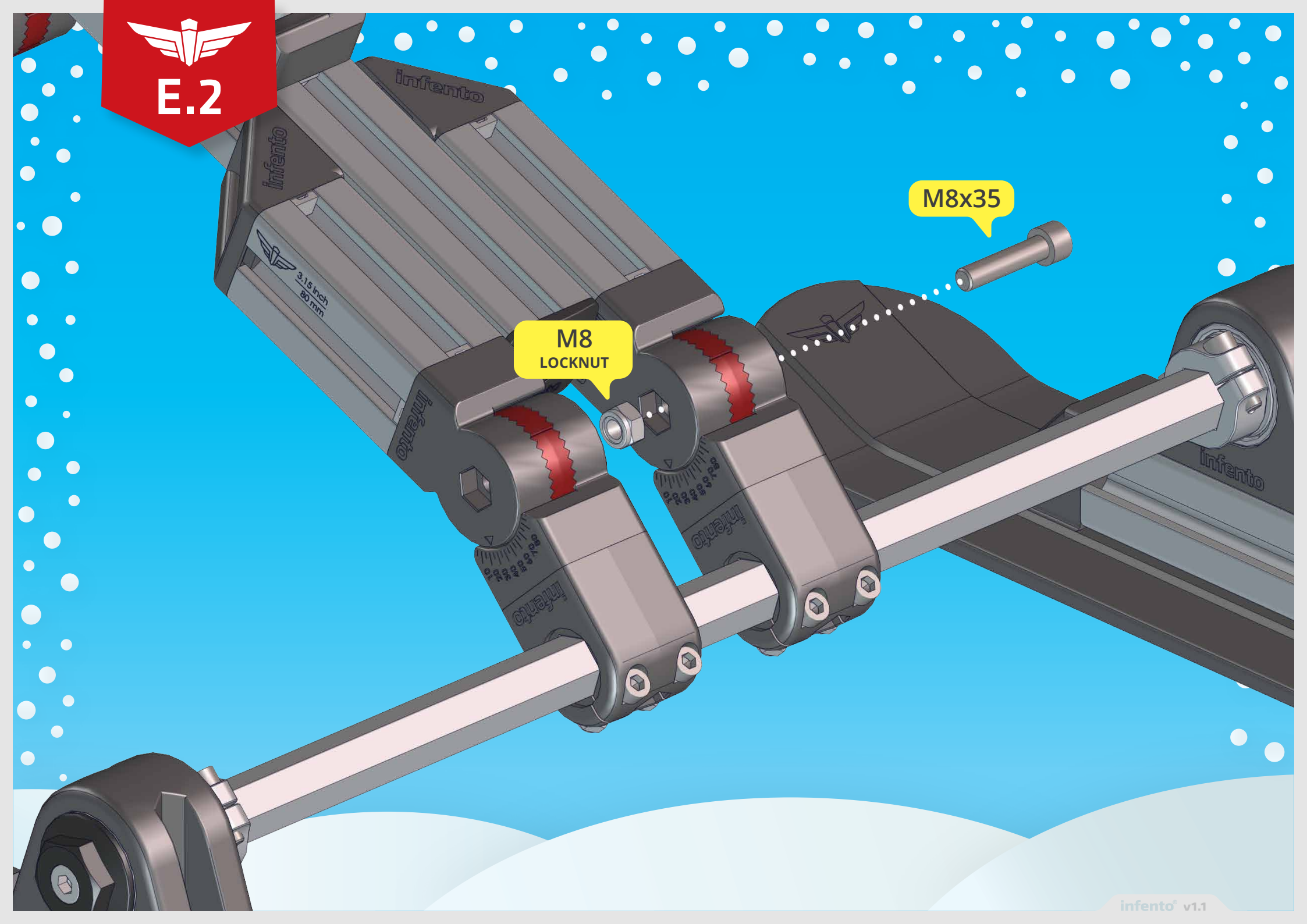



E.3

M8x35

M8  
LOCKNUT



Knurled disc  
2 STRIPES



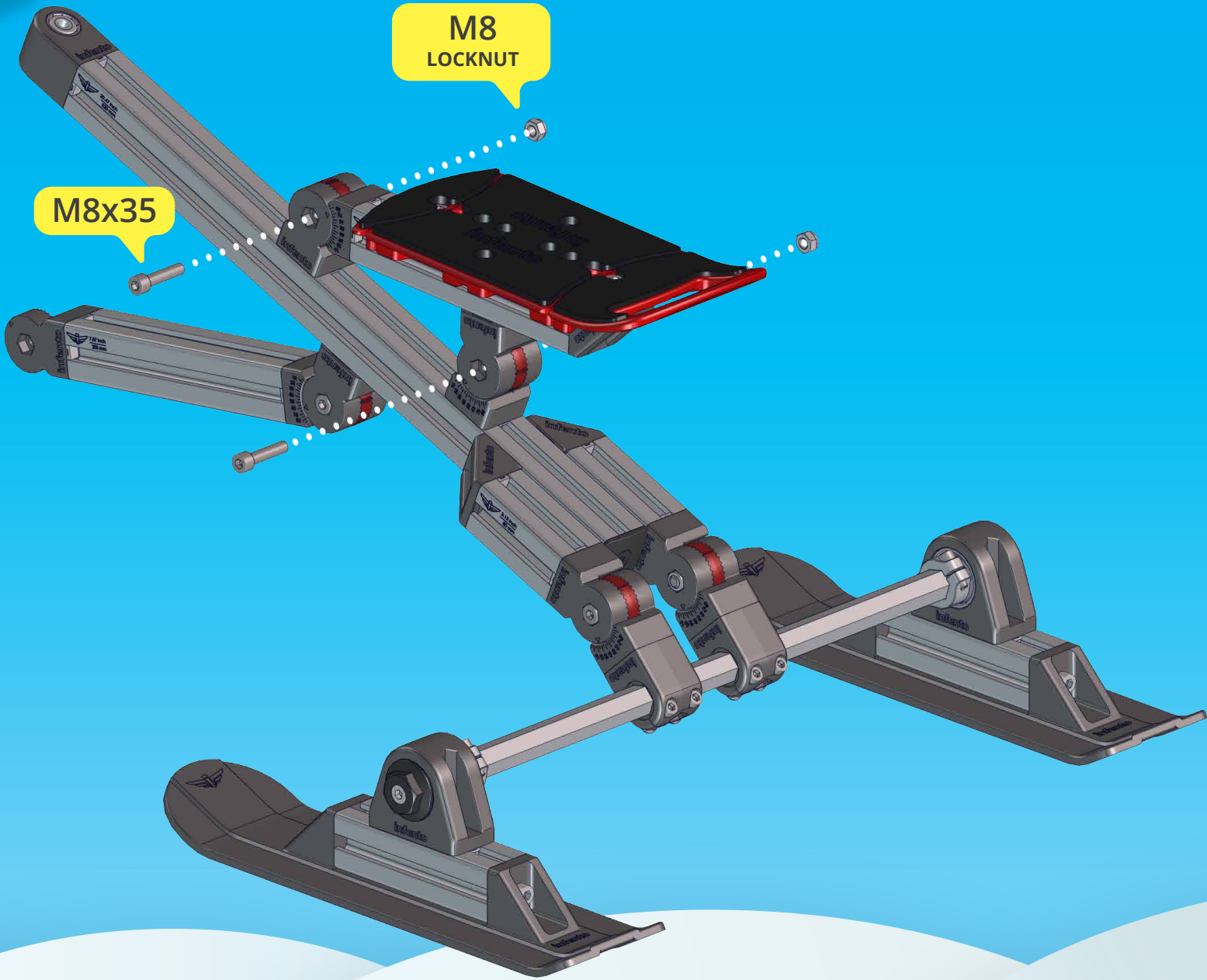

M8  
LOCKNUT

M8x35



E.6

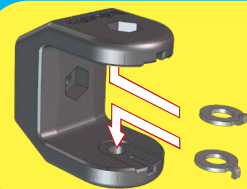

Don't disassemble.  
You can leave  
them in.

If you don't have nock washers,  
use M8-16 washers instead.



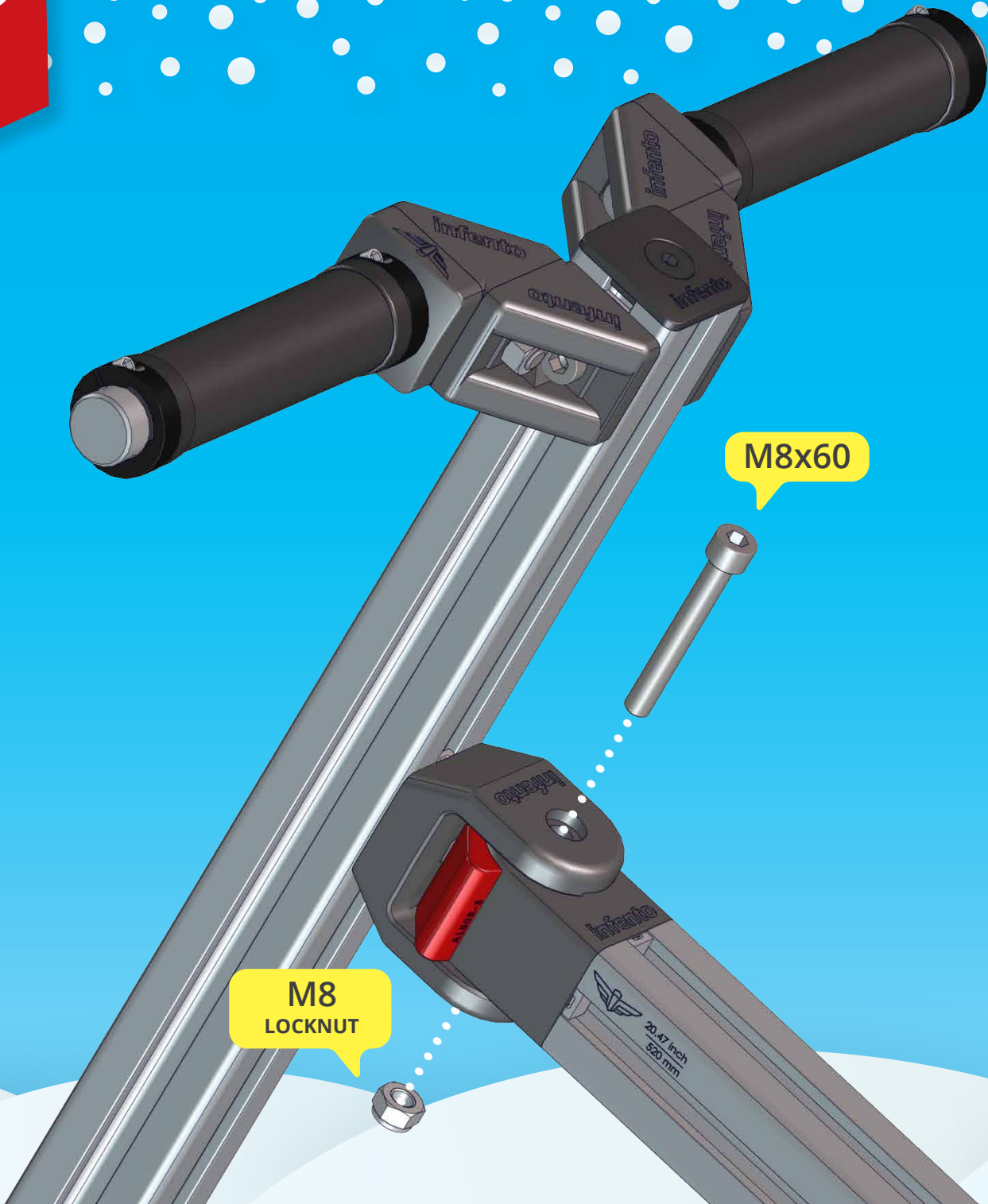

M8x60

M8  
LOCKNUT



E.8

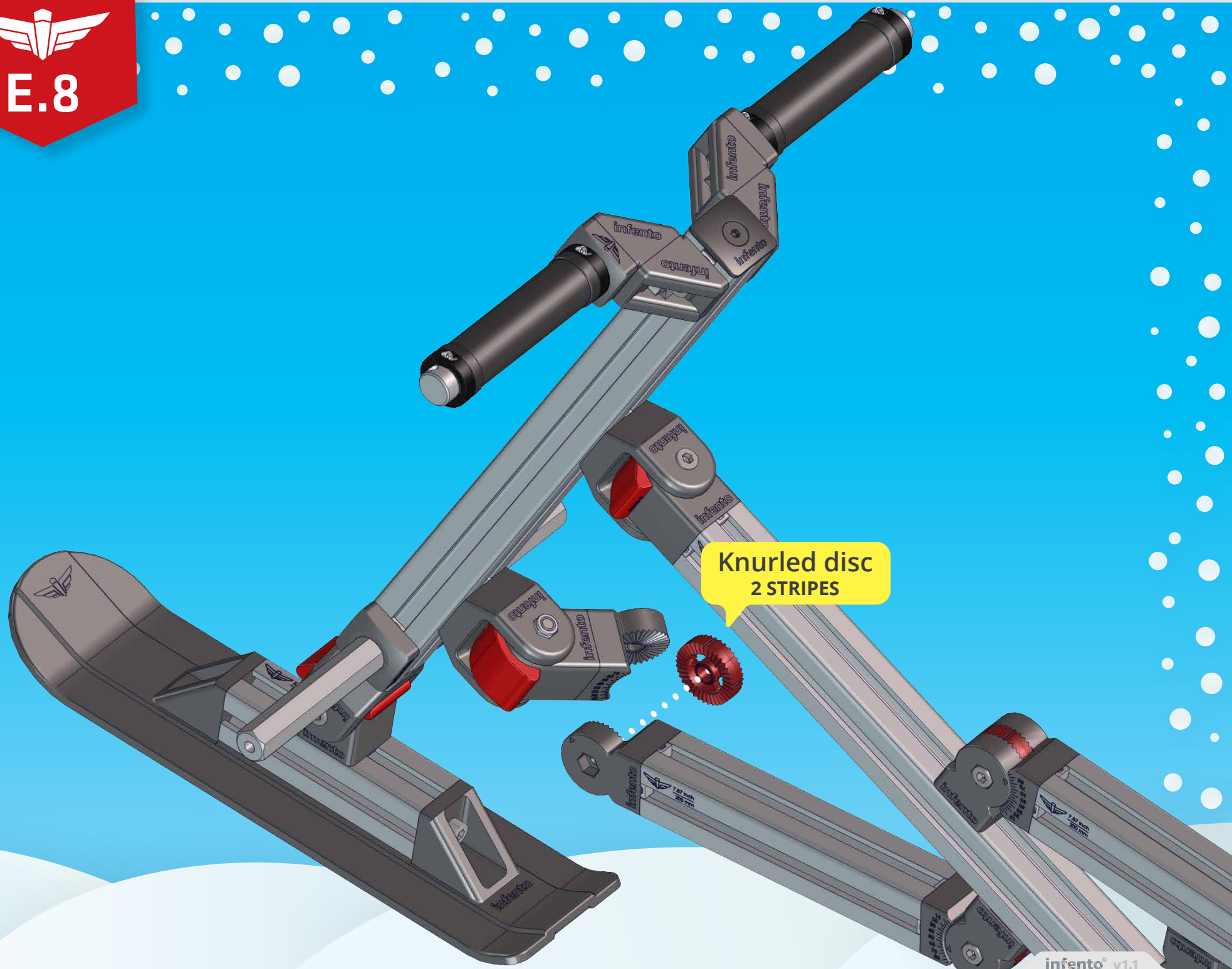

Knurled disc  
2 STRIPES



E.9



M8  
LOCKNUT

M8x35

